

# HIGH EFFICIENCY

Submersible multichannel "high efficiency" pumps - 2/4 pole

Manufacturing partner for:



www.a3-usa.com

Solve & Save  
new generation pumps



Sonda - Probe  
Sonde - Fühler  
Sonda - электрод

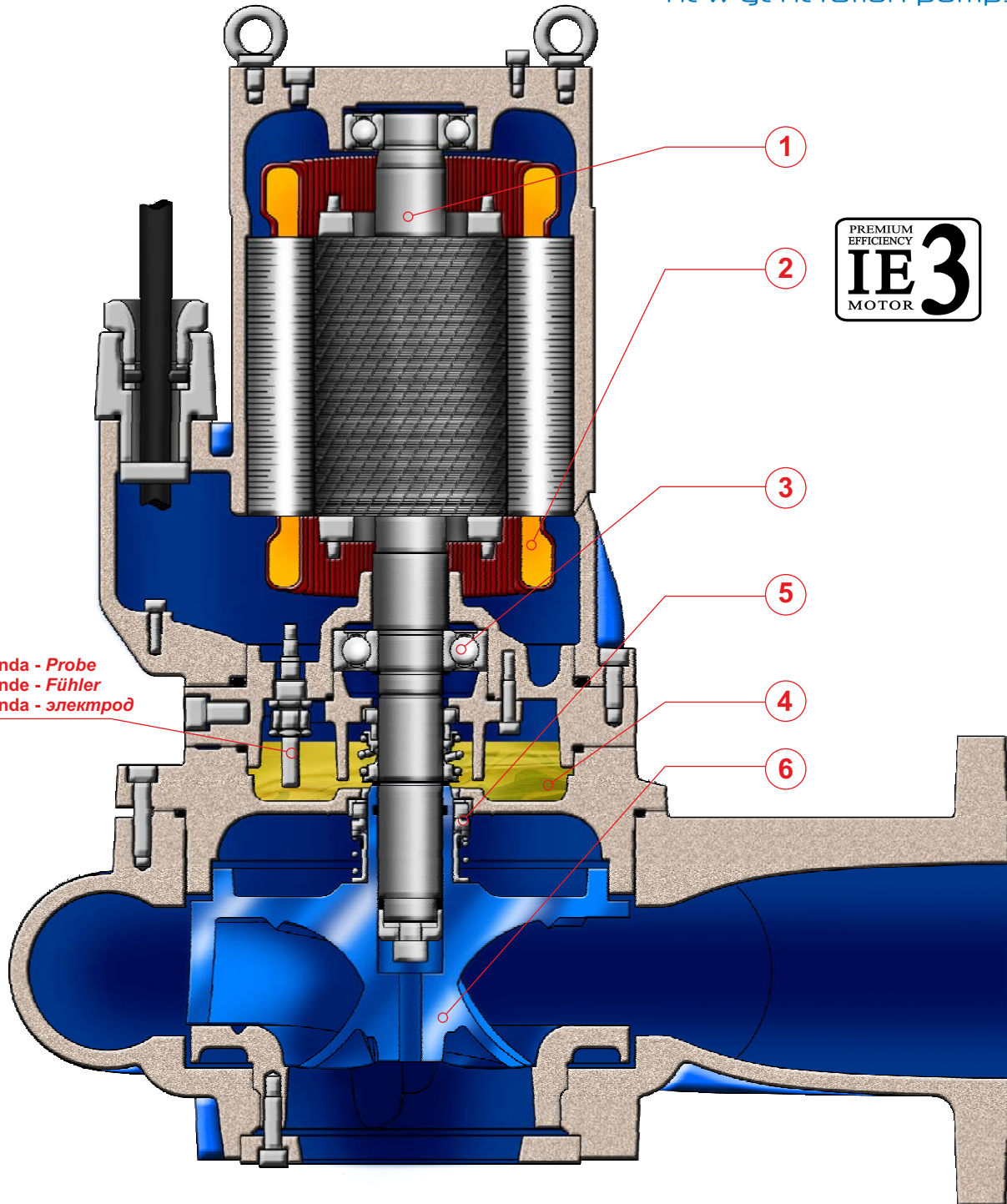

## HIGH EFFICIENCY



- 1 Alberi** rettificati nelle sedi dei cuscinetti e della tenuta, sovradimensionati rispetto ai parametri standard di utilizzo, equilibrati dinamicamente.
- 2 Motore** Asincrono trifase a gabbia di scoiattolo, classe d'isolamento H(180°C). A secco, raffreddato dal liquido circostante. Grado di protezione IP68. Il motore, è progettato per lavoro continuo o intermittente, con un numero non superiore di 15 avviamenti per ora regolarmente distanziati e con un massimo squilibrio di tensione tra le fasi del 5%.
- 3 Cuscinetti** sovradimensionati, radiali a sfere lubrificati a vita esenti da manutenzione.
- 4 Camera olio** L'olio lubrifica e raffredda le tenute, ed emulsiona eventuali infiltrazioni di acqua. La pompa è dotata di due sistemi di tenuta per il perfetto isolamento tra il motore elettrico e il liquido pompato. Tenuta superiore: Ceramica/Grafite.
- 5 Tenuta inferiore:** meccanica, carburo di silicio.
- 6 Le giranti** realizzate con uno speciale profilo palare autopulente anti-intasamento, sono progettate per garantire alto rendimento idraulico e bassi consumi energetici.



- 1 Les arbres** rectifiés dans les sièges des roulements et de la garniture mécanique, surdimensionnés par rapport aux paramètres standard d'utilisation, équilibrés dynamiquement.
- 2 Moteur** asynchrone triphasé à cage d'écureuil, classe d'isolation H(180°C). À sec, refroidi par le liquide environnant. Degré de protection IP68. Le moteur est dessiné pour le service continu ou intermittent, avec un nombre de démarrages inférieur à 15/h, régulièrement espacés et avec max. 5% de déséquilibre de tension entre les phases.
- 3 Roulements** surdimensionnés, radiaux, à sphères lubrifiées à vie, exemptes d'entretien.
- 4 Chambre huile** L'huile lubrifie et refroidit les garnitures mécaniques et émulsionne les infiltrations d'eau éventuelles. Deux garnitures mécaniques assurent la parfaite isolation entre le moteur électrique et le liquide pompé. Garniture supérieure: céramique/carbone.
- 5 Garniture inférieure:** mécanique, carbure de silicium.
- 6 Rotors:** construits avec une lame profil autonettoyant et anti-colmatage spécial, sont conçus pour offrir un rendement hydraulique élevé et basse consommation d'énergie.



- 1 Ejes** rectificado en la base de los cojinetes y base de la mecánica, sobredimensionado respecto a los parámetros estándar de uso y equilibrados dinámicamente.
- 2 Motor** asincrónico trifásico con jaula, aislamiento H(180°C). En seco, enfriado por el líquido. Grado de protección IP68. El motor, esta preparado para trabajar continuamente o intermitentemente, con un numero de encendidos nunca superior a 15 /ora y con un máximo desequilibrio de tensión entre las fases del 5%.
- 3 Cojinetes** sobredimensionados, radiales y esferas lubricados indefinidamente, sin necesidad de mantenimiento.
- 4 Cámara de aceite** que lubrica y enfría los precintos y emulsiona las eventuales infiltraciones de agua. La bomba está dotada de dos sistemas de sellado para el perfecto aislamiento entre el motor eléctrico y el líquido bombeado. Sellado/precintado superior: mecánica, grafito/cerámica.
- 5 Sellado/precintado inferior:** mecánica, carburo y silicio.
- 6 Impulsores:** hechos con una hoja de perfil autolimpiador, anti-obstrucción, están diseñados para garantizar un alto rendimiento hidráulico y bajo consumo de energía.



- 1 Shafts** grided down in ball bearings and mechanical seals seats, over-dimensioned respect to standard parameters of use.
- 2 Motor** asynchronous threephase squirrel cage type, insulation class H(180°C). Dry motor, cooled by surrounding liquid. Protection degree IP 68. The motor is projected for continuous or intermittent operation, with a maximum of 15 starts per hour at regular intervals. The motor is projected for working with 5% maximum voltage unbalance between phases.
- 3 Ball bearings** overdimensioned, life lubricated, maintenance free.
- 4 Oil chamber** oil lubricates and cools the seals and emulsifies eventual water infiltrations. This electric pump has two types of seals for a perfect insulation between the electric motor and the pumped liquid. Upper seal: Ceramic/Graphite.
- 5 Lower seal:** mechanical, silicon carbide.
- 6 Rotors:** made with a special self-cleaning anti-clogging blade profile, they are designed to provide high hydraulic efficiency and low energy consumption.



- 1 Welle** Lagerung und Abdichtung durch überdimensionierte Wälzlager bzw. Dichtungsträger.
- 2 Motor** Asynchronmotor dreiphasig als Käfigläufer, Isolationsklasse H(180°C). Trockenläufer und Kühlung durch die umgebende Flüssigkeit. Schutzart IP 68. Der Motor ist für Dauerbetrieb und Aussetzbetrieb mit max. 15 Schaltspielen pro Stunde sowie für Spannungstoleranzen von +/- 5% ausgelegt.
- 3 Wälzlager** überdimensioniert, dauergeschmiert und wartungsfrei.
- 4 Ölkammer** Öl schmiert und kühlt die Dichtungen und emulgiert bei evtl. Leckage. Doppeltwirkendes Dichtsystem garantiert optimale Abdichtung zwischen Motor und Fördermedium. Obere Dichtung: Gleitringdichtung Kohle / Keramik.
- 5 Untere Dichtung:** Gleitringdichtung Siliziumkarbid.
- 6 Mehrkanallaufblätter:** die Mehrkanallaufblätter weisen ein spezielles selbstreinigendes Schaufelprofil auf. Sie sind für den hohen hydraulischen Wirkungsgrad und niedrigen Energieverbrauch ausgelegt.



- 1 Валы,** отшлифованные в местах посадки подшипников и уплотнения, рассчитанные с запасом относительно стандартных рабочих параметров, динамически отбалансированы.
- 2 Трехфазный** асинхронный двигатель, короткозамкнутый, класс изоляции H (180°C). Сухого типа, охлаждение окружающей жидкостью. Степень защиты IP68. Двигатель предусмотрен для непрерывной работы или работы с перерывами, с максимальным количеством включений - 15 в час с равномерными интервалами, максимальные перепады напряжения между фазами - 5%.
- 3 Подшипники** рассчитаны с запасом, радиального типа с шариками со смазкой на весь срок службы, не требующие тех. обслуживания.
- 4 Масляная** камера служит для смазки и охлаждения прокладок, а также для эмульгирования просочившейся воды. Насос снабжен двумя системами герметизации для обеспечения идеальной изоляции между электродвигателем и перекачиваемой жидкостью. Верхнее уплотнение: керамика/графит.
- 5 Нижнее уплотнение:** механическое, карбид кремния.
- 6 Рабочие** колеса имеют специальный профиль лопастей для самоочистки и предотвращения засорения. Они спроектированы для обеспечения высокого гидравлического КПД и низкого энергопотребления.

# HIGH EFFICIENCY



## IMPIEGHI

Le elettropompe sommergibili multicanale ad "alto rendimento" con profilo palare autopulente possono essere utilizzate in quasi tutte le applicazioni; sono impiegate prevalentemente per il pompaggio di reflui civili anche non grigliati, contenenti corpi solidi e materiali fibrosi, acque di processo, fanghi civili e industriali, pozzi di raccolta acque usate in generale.

### PARTICOLARITÀ COSTRUTTIVE

Elettropompe sommergibili di robusta e compatta costruzione, motori elettrici alloggiati in vano a tenuta stagna, collegati mediante alberi di lunghezze ridotte alle giranti situate in voluta tramite interposizione di camera olio tra parte idraulica e motore elettrico.

### MATERIALI

Fusioni principali	Ghisa EN-GJL-250
Girante	Ghisa GS400 / AISI316L
Cavo elettrico	Neoprene H07RN/F
Albero	Acciaio inossidabile AISI 431
O-rings e paraolio	Nitrile
Bullonerie	Classe A2 - A4
Tenuta meccanica	Carburo di silicio / Carburo di silicio



## APPLICATIONS

Les pompes submersibles multivoies de «haute performance avec pales autonettoyantes peuvent être utilisées dans n'importe quelle application ; elles sont principalement utilisées pour le pompage des effluents domestiques également pas grillés, contenant des matières solides et des matériaux fibreux, eaux de traitement, boues civiles et industrielles, puits pour la collecte des eaux usées en général.

### PARTICULARITÉ DE CONSTRUCTION

Pompes submersibles robustes et compactes, moteurs électriques logés en enceinte étanche, reliés par des arbres de longueurs réduites aux roues, avec interposition d'une chambre à huile entre la partie hydraulique et le moteur électrique.

### MATÉRIAUX

Moulures principales	Fonte EN-GJL-250
Roue	Fonte Sferoidale GS400 / AISI316L
Câble électrique	Néoprène H07RN/F
Arbre	Acier inoxydable AISI 431
O-ring et joints	Nitrile
vis	Classe A2 - A4
Garniture mécanique	Carb. de silicium / carbure de silicium



## UTILIZACION

Las electro-bombas sumergibles multicanales de "alto rendimiento" con perfil de auto-limpieza de la hoja pueden ser utilizadas en casi cualquier aplicación; son utilizadas principalmente para el bombeo de aguas residuales, sin rejillas, que contienen cuerpos sólidos y materiales fibrosos, aguas de proceso, lodos civiles e industriales, colectores de aguas residuales en general.

### DIFERENCIAS PRINCIPALES

Son bombas sumergibles de robusta y compacta construcción, motores eléctricos situados en compartimento separado, conectadas mediante ejes cortos con los impulsores interpuestos con una cámara de aceite entre la parte hidráulica i el motor eléctrico.

### MATERIALES

Aleaciones principales	Hierro Fundido EN-GJL-250
Impulsor (turbina)	Hierro Fundido GS400 / AISI316L
Cable eléctrico	Neopreno H07RN/F
Eje	Acero inoxidable AISI 431
Anillo de sellados y O-Rings	Nitrilo
Tornillos	Clase A2 - A4
Sello mecánico	Carburo de silicio / Carburo de silicio



## APPLICATION

The submersible multichannel "high performance" pumps with self-cleaning blade profile can be used in almost any application; they are mainly used for the pumping of domestic effluent containing solids and fibrous materials, process water, civil and industrial sludge, waste water sumps in general.

### CONSTRUCTION DATA

Submersible electric pumps, robust in construction, watertight electric motors accommodated in compartment, connected, by shafts of reduced lengths, to the impellers situated at the pump casing by the interposition of oil chamber between the hydraulic side and the electric motor.

### MATERIALS

Motor housing	Cast iron EN-GJL-250
Impeller	Cast-iron GS400 / AISI316L
Electric cable	Neoprene H07RN/F
Shaft	Stainless Steel AISI 431
O-rings and lip seal	Nitrile
Bolts	A2 - A4 class
Mechanical seal	Silicon Carbide / Silicon Carbide



## EINSATZBEREICHE

Die Hochleistungs-Tauchmotorpumpen mit Mehrkanallaufwerk mit selbstreinigendem Schaufelprofil bieten vielfältige Einsatzmöglichkeiten. Sie werden vorwiegend zur Förderung von häuslichen auch nicht gefilterten Abwässern mit Fest- und Faserstoffgehalt, Prozesswasser, Schlamm, gesammeltes Wasser.

### AUSFÜHRUNG

Robuste Tauchmotorpumpe mit wasserdichtem Motor, kompakte Bauart, Laufwerk im Pumpengehäuse durch Ölkammer zum Motor getrennt.

### WERKSTOFFE

Motorgehäuse	Grauguss EN-GJL-250
Laufwerk	Sphäroguss GS400 / AISI316L
Anschlusskabel	Neoprene H07RN/F
Welle	Edelstahl AISI 431
Wellendichtring und O-Ringe	Nitril
Schrauben	Edelstahl A2 - A4
Gleitringdichtung	Siliziumkarbid / Siliziumkarbid



## ОБЛАСТЬ ПРИМЕНЕНИЯ

Многоканальные погружные насосы высокой производительности с самоочищающимся профилем могут использоваться почти для любых применений; они используются, в основном, для перекачки хозяйственных стоков, в том числе неочищенных, с содержанием твердых частиц и волокнистых материалов, технической воды, промышленных и бытовых отходов и, в целом, для отстойников сточных вод.

### КОНСТРУКЦИОННЫЕ ОСОБЕННОСТИ

Погружные электронасосы с прочной и компактной конструкцией. Электродвигатели размещены в секции с герметичным уплотнением и соединены через валы небольшой длины с рабочими колесами, расположенными в гидравлической камере. Валы проходят через масляную камеру между гидравликой и электродвигателем.

### МАТЕРИАЛЫ

Основные литые компоненты	Чугун EN-GJL-250
Рабочее колесо	Чугун GS400 / AISI316L
Электрокабель	Неопрен H07RN/F
Вал	Нержавеющая сталь AISI 431 / Дуплекс
Уплот. кольца и манжета	Нитрил
Винты	Класс A2 - A4
Мех. Уплотнение	Карбид кремния/Карбид кремния.

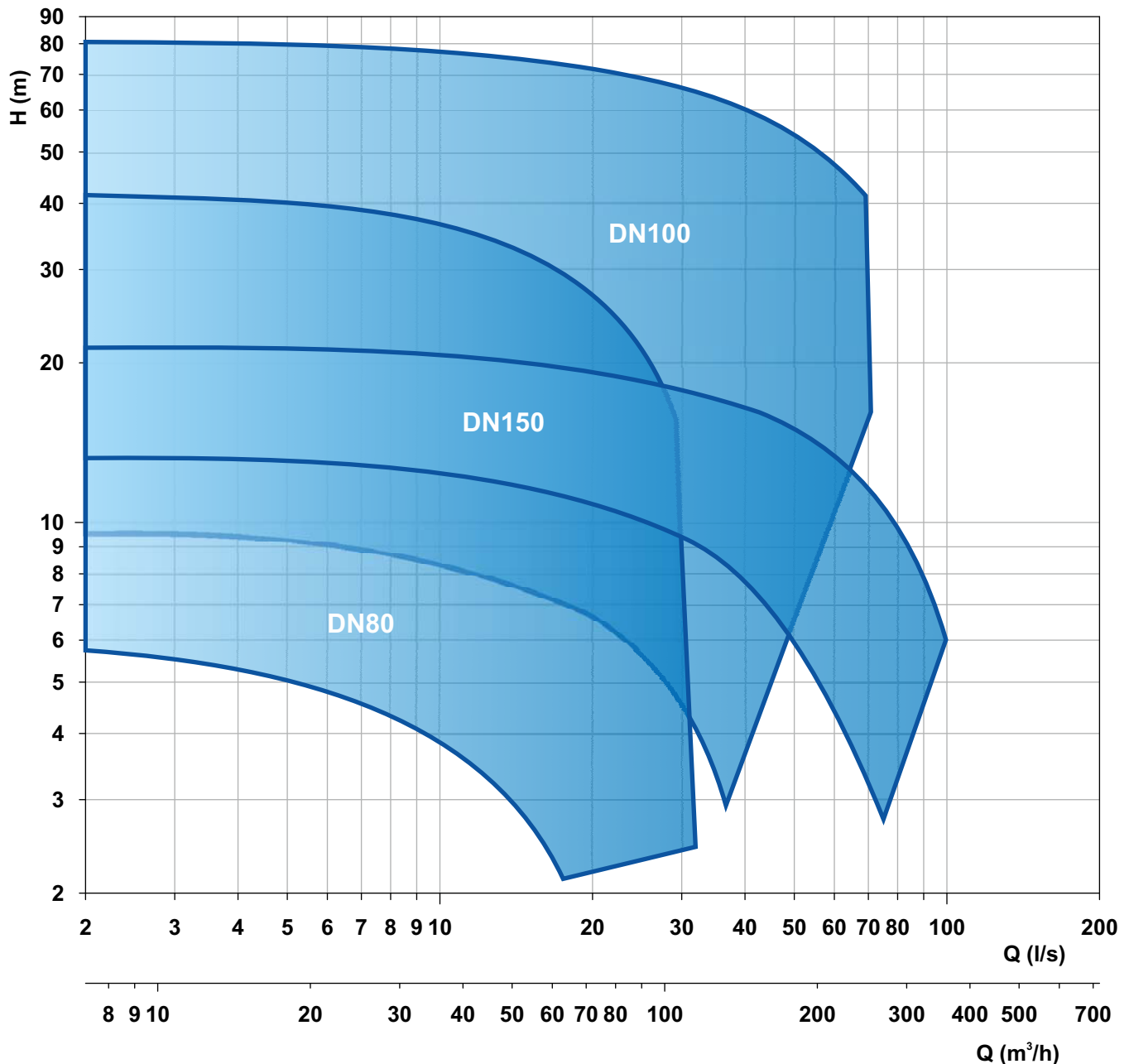

## HIGH EFFICIENCY

Elettropompe sommergibili multicanale "alto rendimento" 2/4 poli  
 Submersible multichannel pumps of "high efficiency" 2/4-pole  
 Pompes submersibles multivoies "à haut rendement" 2/4 pôles  
 Tauchmotorpumpen mit Mehrkanallauftrad "Hochleistung" 2/4-polig  
 Electro-Bombas sumergibles multicanales de "alta eficiencia" 2/4 polos  
 Многоканальные погружные насосы с высоким КПД 2/4 полюса

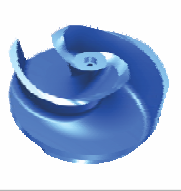

Le schede tecniche sono disponibili al sito [www.faggiolatipumps.com](http://www.faggiolatipumps.com)  
 Technical data sheets are available on our web site [www.faggiolatipumps.com](http://www.faggiolatipumps.com)  
 Les fiches techniques sont disponibles sur notre site web [www.faggiolatipumps.com](http://www.faggiolatipumps.com)  
 Technische Datenblätter finden Sie auf unserer Internetseite [www.faggiolatipumps.com](http://www.faggiolatipumps.com)  
 Las hojas de datos técnicas están disponibles en nuestro web site [www.faggiolatipumps.com](http://www.faggiolatipumps.com)  
 Технические спецификации доступны на веб-сайте [www.faggiolatipumps.com](http://www.faggiolatipumps.com)



 Ghisa EN-GJL-250  
 Fonte EN-GJL-250  
 Hierro fundido EN-GJL-250

 Cast Iron EN-GJL-250  
 Grauguss EN-GJL-250  
 Чугун EN-GJL-250

Curva caratteristica - Performance curve - Courbe caractéristique  
 Kennlinie - Curva característica - Характеристическая кривая

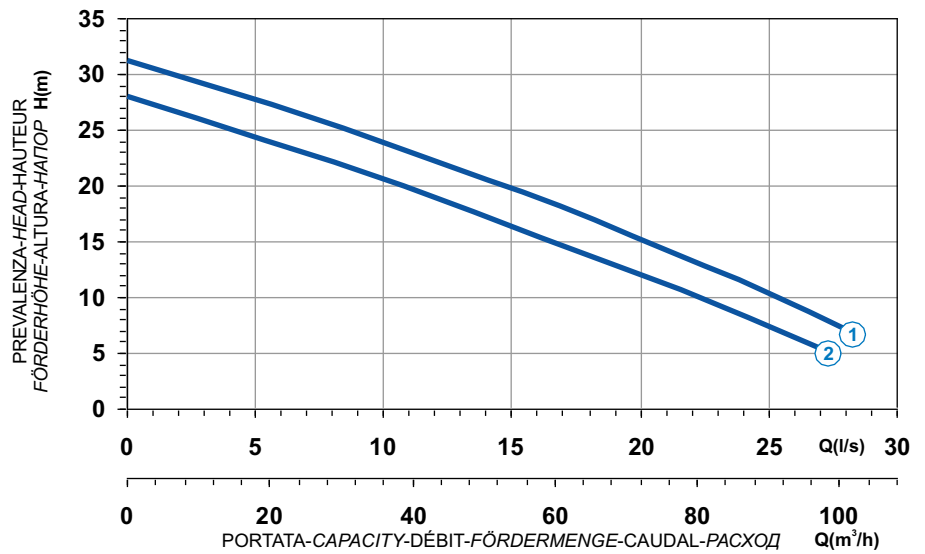





Power supply	3ph 400/690V 50Hz
R.P.M.	2850
Free passage (mm)	25
Discharge (mm)	DN 80
Max Weight (Kg)	87

Curve N°	Code	Type	MOTOR			ATEX code 
			Rated power P2 (kW)	Rated current I (A)	Starting current Is (A)	
1	7001344	G210R2H1-M25AA2	6	10,9	64,3	7005951
2	7005051	G210R2H3-M25AA2	5,7	10,4	61,4	7004875

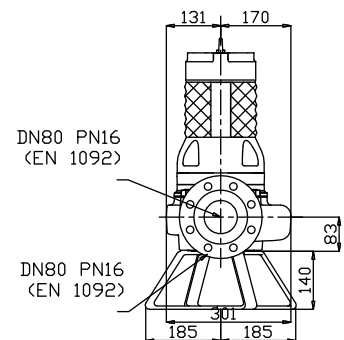
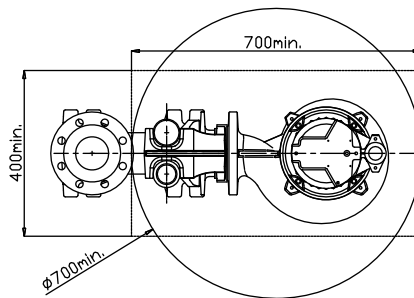
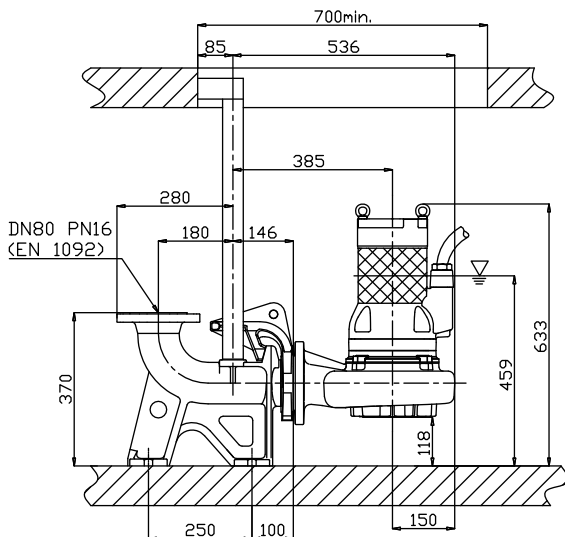
## Dimensioni - Dimensions - Dimensions - Abmessungen - Dimensiones - Габариты (mm)

▽ LIVELLO MINIMO DI SOMMERGIBILITÀ  
 MINIMUM SUBMERSIBLE LEVEL  
 NIVEAU MINIMUM D'IMMERSION  
 MINDESTWASSERSTAND  
 NIVEL SUMERGIBLE MÍNIMO  
 МИНИМАЛЬНАЯ ГЛУБИНА ПОГРУЖЕНИЯ



 Ghisa EN-GJL-250  
 Fonte EN-GJL-250  
 Hierro fundido EN-GJL-250

 Cast Iron EN-GJL-250  
 Grauguss EN-GJL-250  
 Чугун EN-GJL-250

Curva caratteristica - Performance curve - Courbe caractéristique  
 Kennlinie - Curva característica - Характеристическая кривая

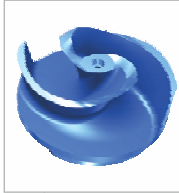
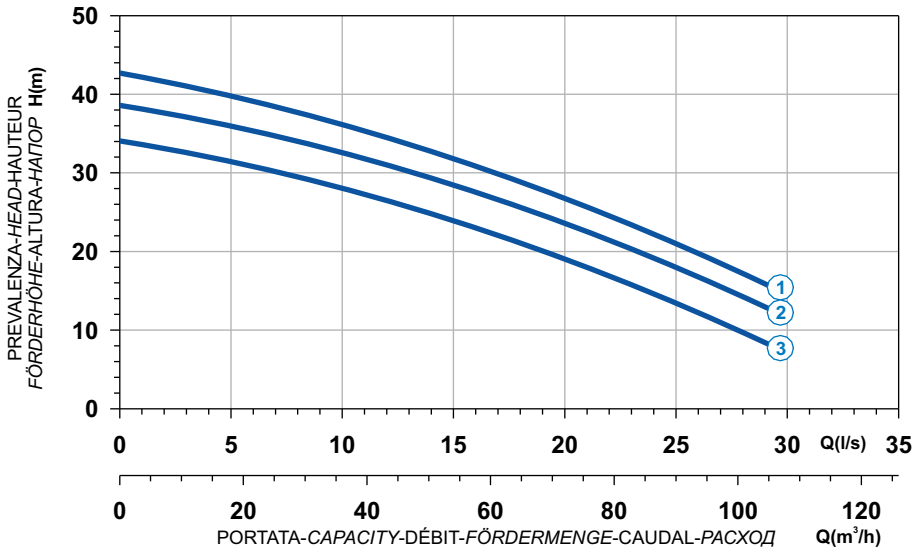

H

Curve N°	Code	Type	MOTOR			ATEX code 
			Rated power P2 (kW)	Rated current I (A)	Starting current Is (A)	
1	7006980	G211R2H1-M30AA2	10	18	106	7008344
2	7007007	G211R2H2-M30AA2	9	16,2	95,6	7008579
3	7007029	G211R2H3-M30AA2	7,5	13,5	79,6	7008580

Power supply	3ph 400/690V 50Hz
R.P.M.	2850
Free passage (mm)	60
Discharge (mm)	DN 80
Max Weight (Kg)	164

## Dimensioni - Dimensions - Dimensions - Abmessungen - Dimensiones - Габариты (mm)

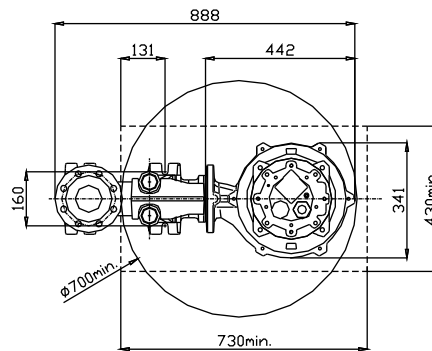
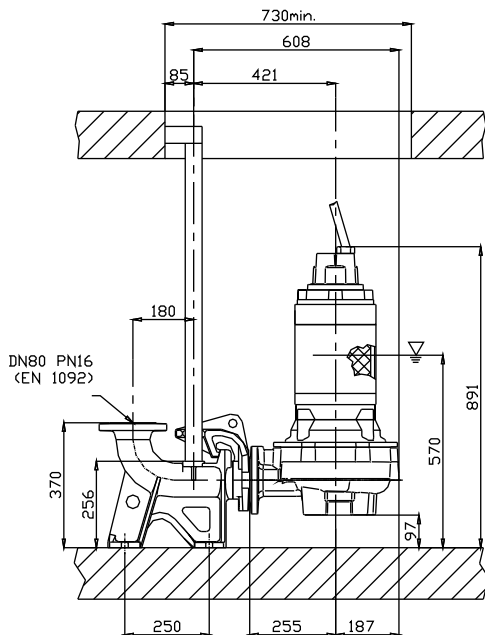

▽ LIVELLO MINIMO DI SOMMERGIBILITÀ  
 MINIMUM SUBMERSIBLE LEVEL  
 NIVEAU MINIMUM D'IMMERSION  
 MINDESTWASSERSTAND  
 NIVEL SUMERGIBLE MÍNIMO  
 МИНИМАЛЬНАЯ ГЛУБИНА ПОГРУЖЕНИЯ

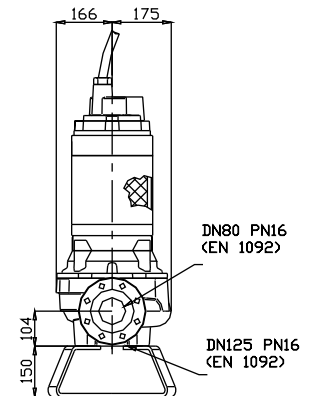

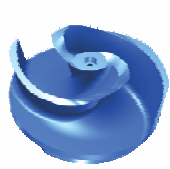

Ghisa EN-GJL-250  
 Fonte EN-GJL-250  
 Hierro fundido EN-GJL-250

Cast Iron EN-GJL-250  
 Grauguss EN-GJL-250  
 Чугун EN-GJL-250

Curva caratteristica - Performance curve - Courbe caractéristique  
 Kennlinie - Curva característica - Характеристическая кривая

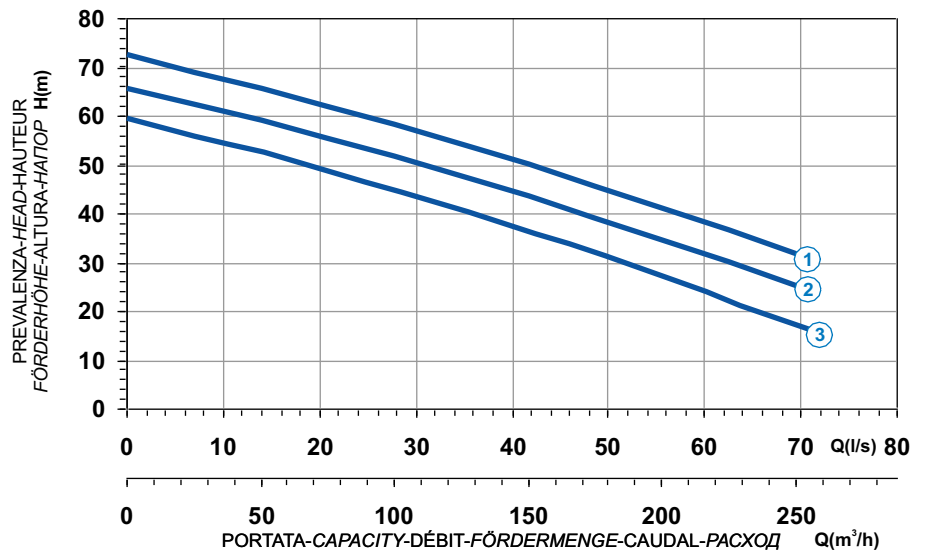





Power supply	3ph 400/690V 50Hz
R.P.M.	2850
Free passage (mm)	40
Discharge (mm)	DN 100
Max Weight (Kg)	375

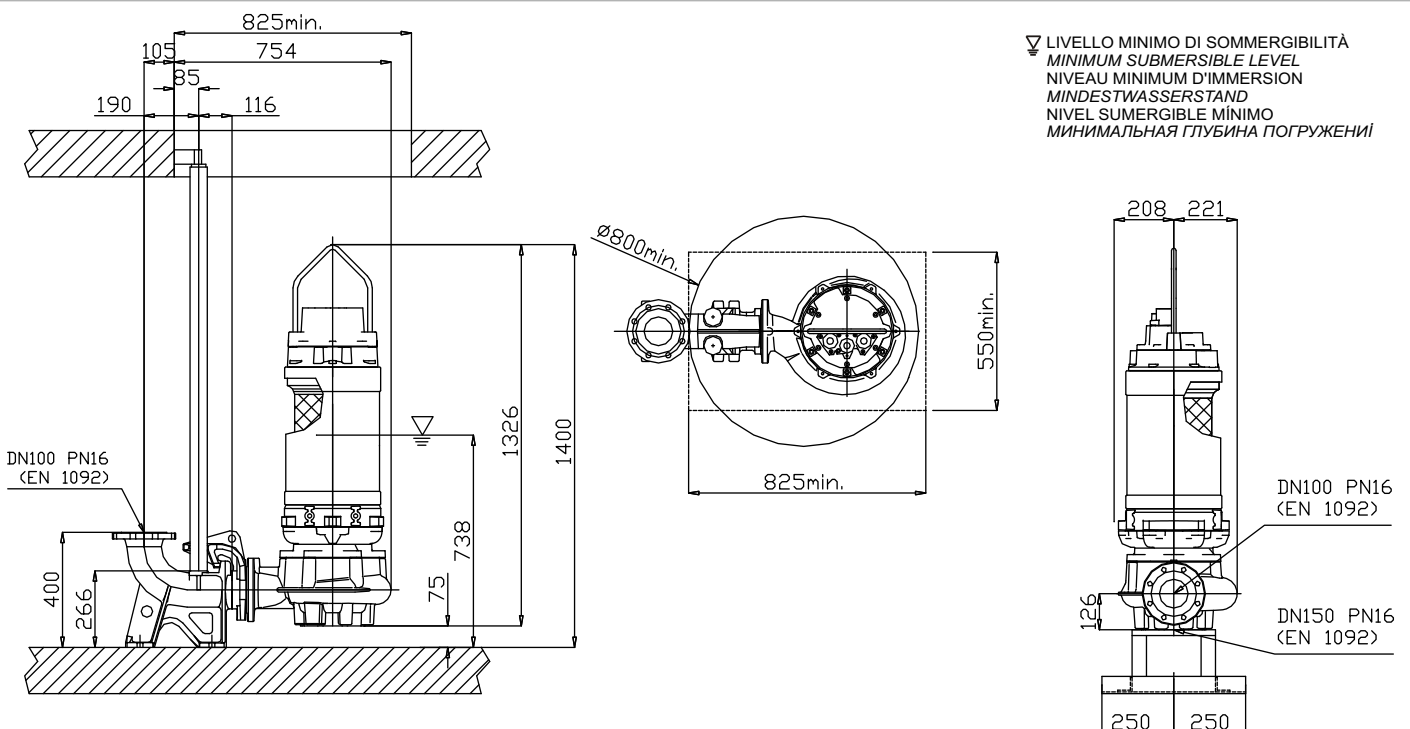

Curve N°	Code	Type	MOTOR			ATEX code
			Rated power P2 (kW)	Rated current I (A)	Starting current Is (A)	
1	7001293	G216R2H1-P40KA2	40	70,6	416	7005232
2	7008360	G216R2H2-P40KA2	33,4	58,5	345	7005628
3	7009056	G216R2H3-P40KA2	27	46,9	277	7005627

### Dimensioni - Dimensions - Dimensions - Abmessungen - Dimensiones - Габариты (mm)

▽ LIVELLO MINIMO DI SOMMERGIBILITÀ  
 MINIMUM SUBMERSIBLE LEVEL  
 NIVEAU MINIMUM D'IMMERSION  
 MINDESTWASSERSTAND  
 NIVEL SUMERGIBLE MÍNIMO  
 МИНИМАЛЬНАЯ ГЛУБИНА ПОГРУЖЕНИЯ



 Ghisa EN-GJL-250  
 Fonte EN-GJL-250  
 Hierro fundido EN-GJL-250

 Cast Iron EN-GJL-250  
 Grauguss EN-GJL-250  
 Чугун EN-GJL-250

**Curva caratteristica - Performance curve - Courbe caractéristique**  
**Kennlinie - Curva característica - Характеристическая кривая**

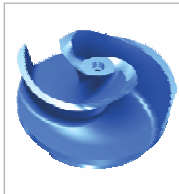
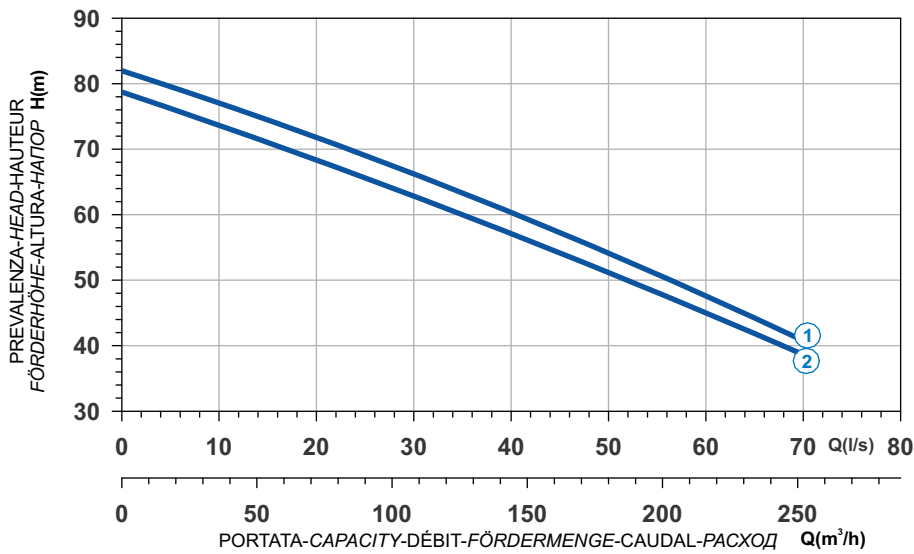

H

Curve N°	Code	Type	MOTOR			ATEX code 
			Rated power P2 (kW)	Rated current I (A)	Starting current Is (A)	
1	7007355	G218R2H2-P40KA2	52	90,1	532	7005635
2	7008619	G218R2H4-P40KA2	45	78,3	462	7009632

Power supply	3ph 400/690V 50Hz
R.P.M.	2850
Free passage (mm)	40
Discharge (mm)	DN 100
Max Weight (Kg)	430

**Dimensioni - Dimensions - Dimensions - Abmessungen - Dimensiones - Габариты (mm)**

▽ LIVELLO MINIMO DI SOMMERGIBILITÀ  
 MINIMUM SUBMERSIBLE LEVEL  
 NIVEAU MINIMUM D'IMMERSION  
 MINDESTWASSERSTAND  
 NIVEL SUMERGIBLE MÍNIMO  
 МИНИМАЛЬНАЯ ГЛУБИНА ПОГРУЖЕНИИ

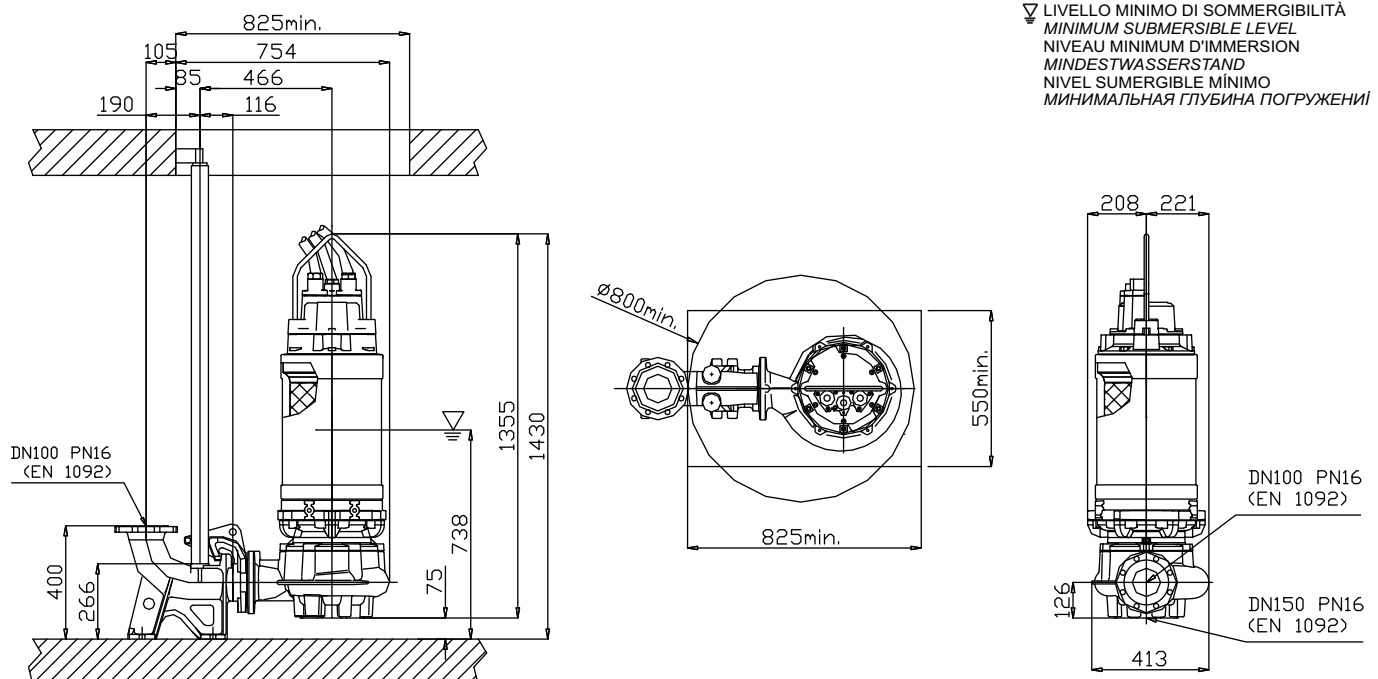



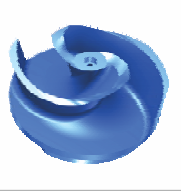

Ghisa EN-GJL-250

Fonte EN-GJL-250

Hierro fundido EN-GJL-250

Cast Iron EN-GJL-250

Grauguss EN-GJL-250

Чугун EN-GJL-250

Curva caratteristica - Performance curve - Courbe caractéristique  
Kennlinie - Curva característica - Характеристическая кривая

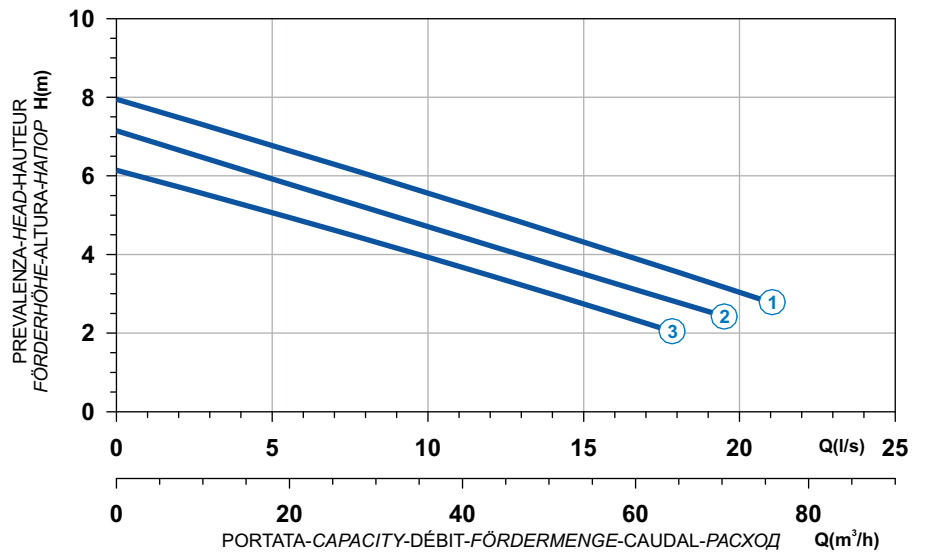



Power supply	3ph 400V 50Hz
R.P.M.	1450
Free passage (mm)	40
Discharge (mm)	DN 80
Max Weight (Kg)	49

Curve N°	Code	Type	MOTOR			ATEX code
			Rated power P2 (kW)	Rated current I (A)	Starting current Is (A)	
1	7004759	G471T2H1-M40AA0	1,6	3,1	13,9	7008507
2	7001513	G471T2H2-M40AA0	1,6	3,1	13,9	7003119
3	7001865	G471T2H3-M40AA0	1,4	2,7	12,1	7008406

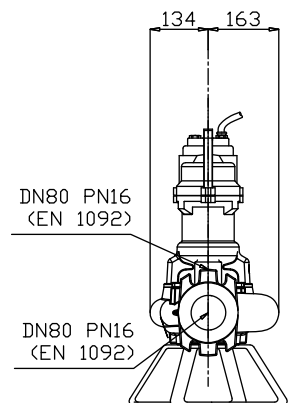
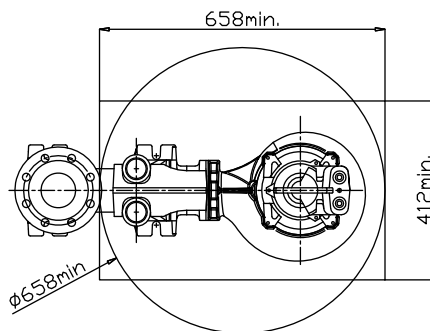
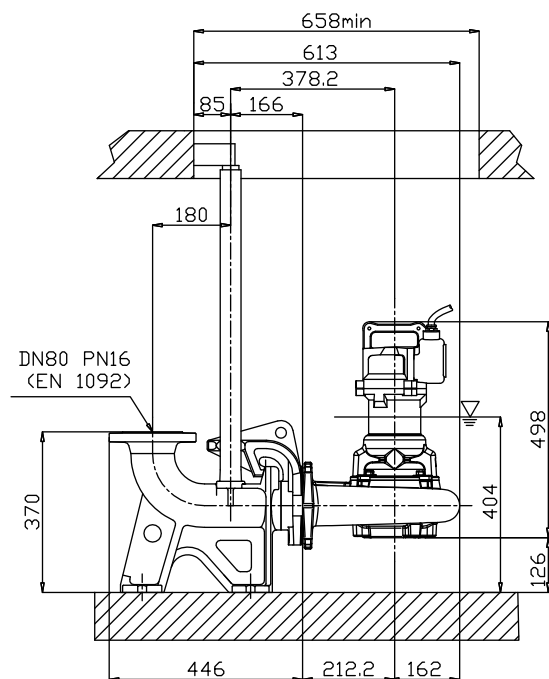
### Dimensioni - Dimensions - Dimensions - Abmessungen - Dimensiones - Габариты (mm)



▽ LIVELLO MINIMO DI SOMMERGIBILITÀ  
MINIMUM SUBMERSIBLE LEVEL  
NIVEAU MINIMUM D'IMMERSION  
MINDESTWASSERSTAND  
NIVEL SUMERGIBLE MÍNIMO  
МИНИМАЛЬНАЯ ГЛУБИНА ПОГРУЖЕНИЯ

 Ghisa EN-GJL-250  
 Fonte EN-GJL-250  
 Hierro fundido EN-GJL-250

 Cast Iron EN-GJL-250  
 Grauguss EN-GJL-250  
 Чугун EN-GJL-250

Curva caratteristica - Performance curve - Courbe caractéristique  
 Kennlinie - Curva característica - Характеристическая кривая

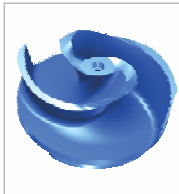
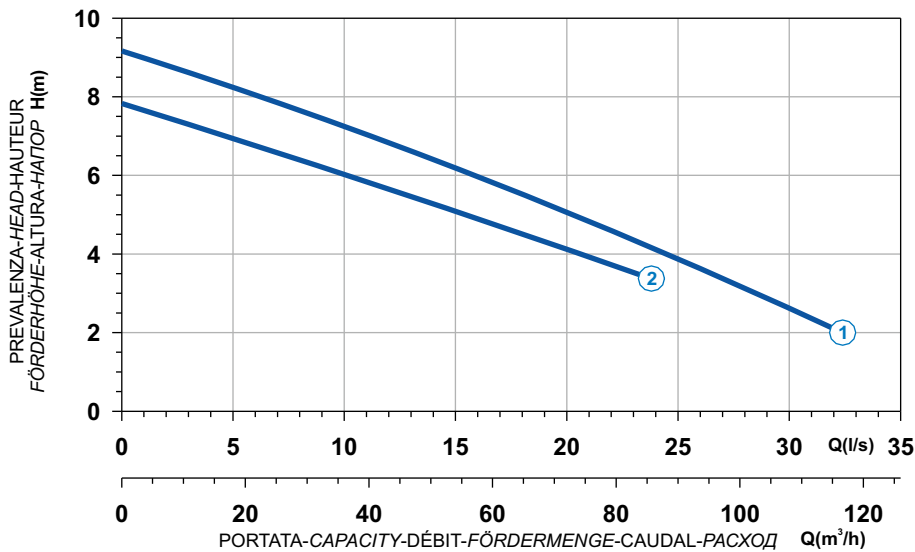

H

Curve N°	Code	Type	MOTOR			ATEX code 
			Rated power P2 (kW)	Rated current I (A)	Starting current Is (A)	
1	7006062	G409T2H2-M50AA0	2,8	5,4	24,3	7008642
2	7008629	G409T2H3-M50AA0	1,9	3,7	16,7	7000142

Power supply	3ph 400V 50Hz
R.P.M.	1450
Free passage (mm)	50
Discharge (mm)	DN 80
Max Weight (Kg)	82

## Dimensioni - Dimensions - Dimensions - Abmessungen - Dimensiones - Габариты (mm)

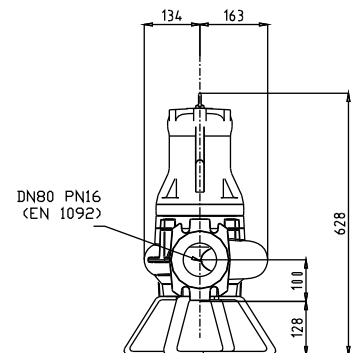
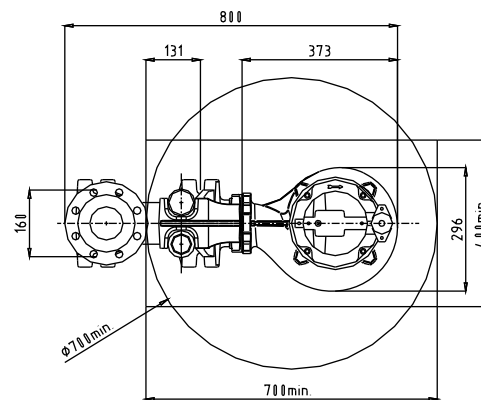
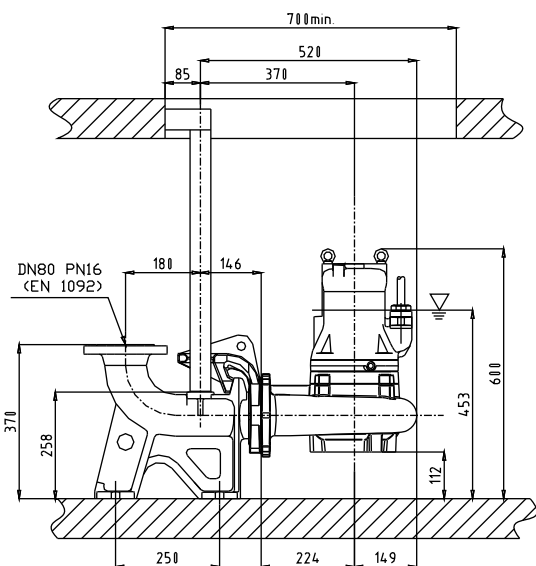

▽ LIVELLO MINIMO DI SOMMERSIBILITÀ  
 MINIMUM SUBMERSIBLE LEVEL  
 NIVEAU MINIMUM D'IMMERSION  
 MINDESTWASSERSTAND  
 NIVEL SUMERGIBLE MÍNIMO  
 МИНИМАЛЬНАЯ ГЛУБИНА ПОГРУЖЕНИЯ

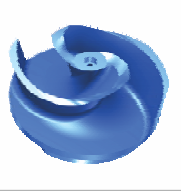

Ghisa EN-GJL-250  
 Fonte EN-GJL-250  
 Hierro fundido EN-GJL-250

Cast Iron EN-GJL-250  
 Grauguss EN-GJL-250  
 Чугун EN-GJL-250

Curva caratteristica - Performance curve - Courbe caractéristique  
 Kennlinie - Curva característica - Характеристическая кривая

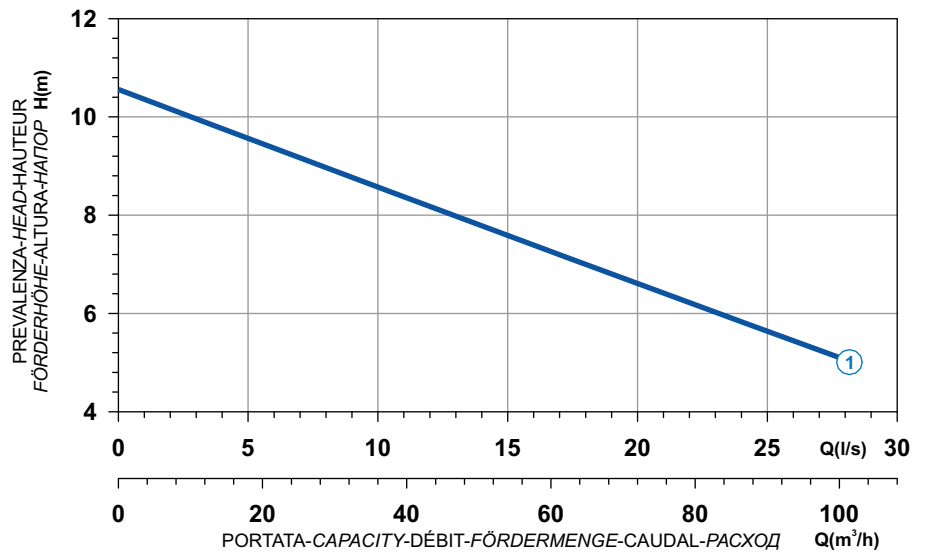





Power supply	3ph 400/690V 50Hz
R.P.M.	1450
Free passage (mm)	50
Discharge (mm)	DN 80
Max Weight (Kg)	86

Curve N°	Code	Type	MOTOR			ATEX code
			Rated power P2 (kW)	Rated current I (A)	Starting current Is (A)	
1	7008320	G410R2H2-M50AA2	3	5,8	26,1	7001860

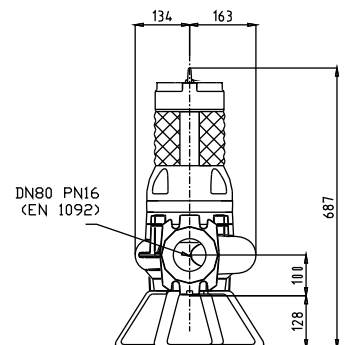
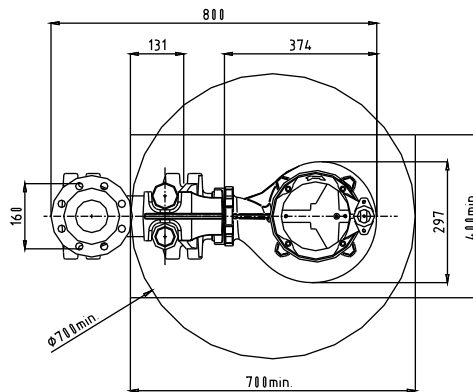
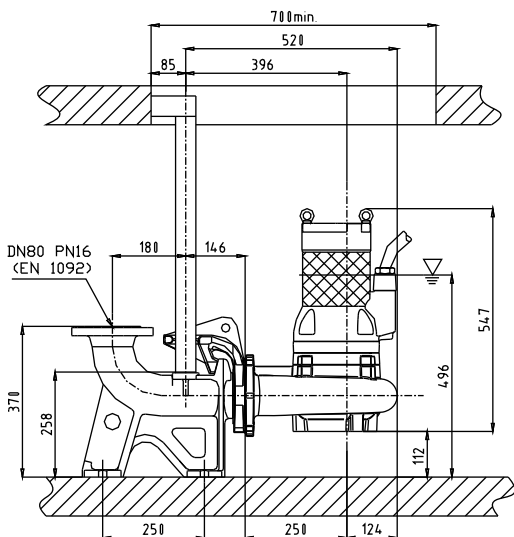
## Dimensioni - Dimensions - Dimensions - Abmessungen - Dimensiones - Габариты (mm)

▽ LIVELLO MINIMO DI SOMMERGIBILITÀ  
 MINIMUM SUBMERSIBLE LEVEL  
 NIVEAU MINIMUM D'IMMERSION  
 MINDESTWASSERSTAND  
 NIVEL SUMERGIBLE MÍNIMO  
 МИНИМАЛЬНАЯ ГЛУБИНА ПОГРУЖЕНИЯ



 Ghisa EN-GJL-250  
 Fonte EN-GJL-250  
 Hierro fundido EN-GJL-250

 Cast Iron EN-GJL-250  
 Grauguss EN-GJL-250  
 Чугун EN-GJL-250

**Curva caratteristica - Performance curve - Courbe caractéristique**  
**Kennlinie - Curva característica - Характеристическая кривая**

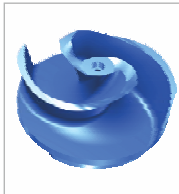
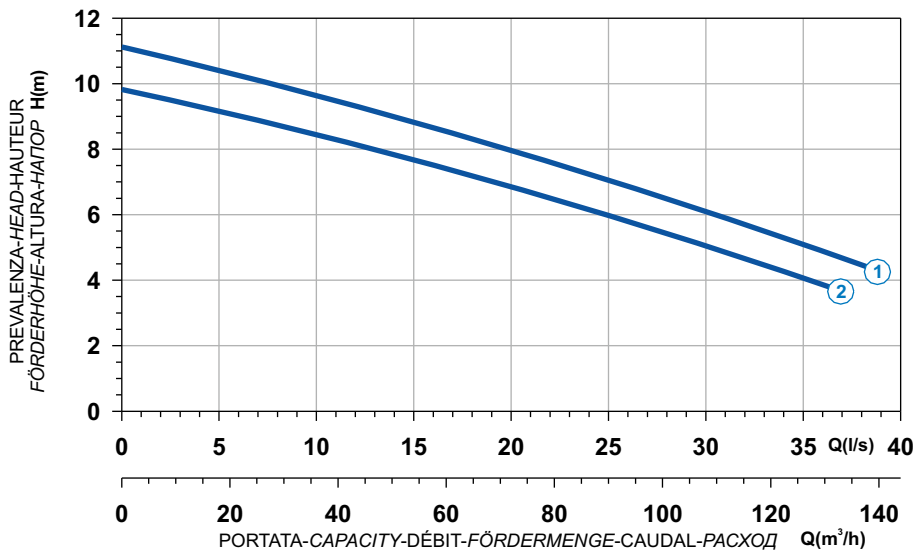

H

Curve N°	Code	Type	MOTOR			ATEX code 
			Rated power P2 (kW)	Rated current I (A)	Starting current Is (A)	
1	7000619	G410R2H3-P50AA2	3,9	7,9	39,5	7001207
2	7008258	G410R2H2-P50AA2	3	5,8	26,1	7009191

Power supply	3ph 400/690V 50Hz
R.P.M.	1450
Free passage (mm)	50
Discharge (mm)	DN 100
Max Weight (Kg)	91

**Dimensioni - Dimensions - Dimensions - Abmessungen - Dimensiones - Габариты (mm)**

▽ LIVELLO MINIMO DI SOMMERGIBILITÀ  
 MINIMUM SUBMERSIBLE LEVEL  
 NIVEAU MINIMUM D'IMMERSION  
 MINDESTWASSERSTAND  
 NIVEL SUMERGIBLE MÍNIMO  
 МИНИМАЛЬНАЯ ГЛУБИНА ПОГРУЖЕНИЯ

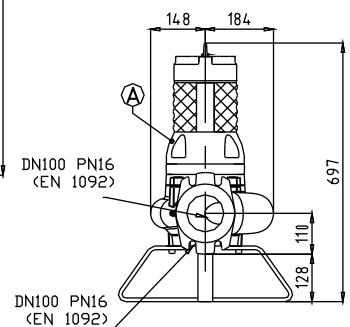
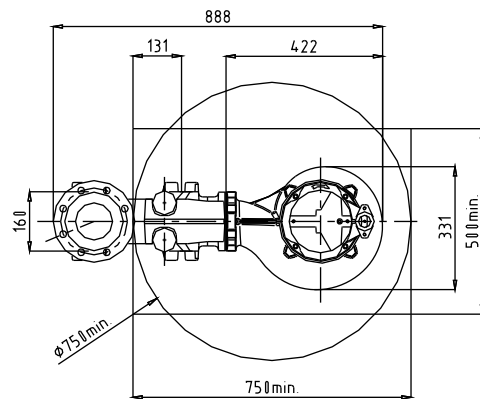
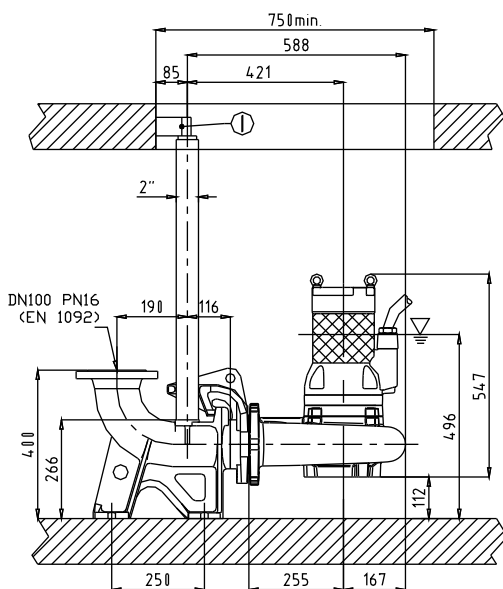

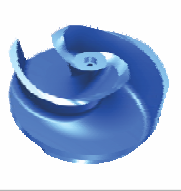

Ghisa EN-GJL-250

Fonte EN-GJL-250

Hierro fundido EN-GJL-250

Cast Iron EN-GJL-250

Grauguss EN-GJL-250

Чугун EN-GJL-250

Curva caratteristica - Performance curve - Courbe caractéristique  
Kennlinie - Curva característica - Характеристическая кривая

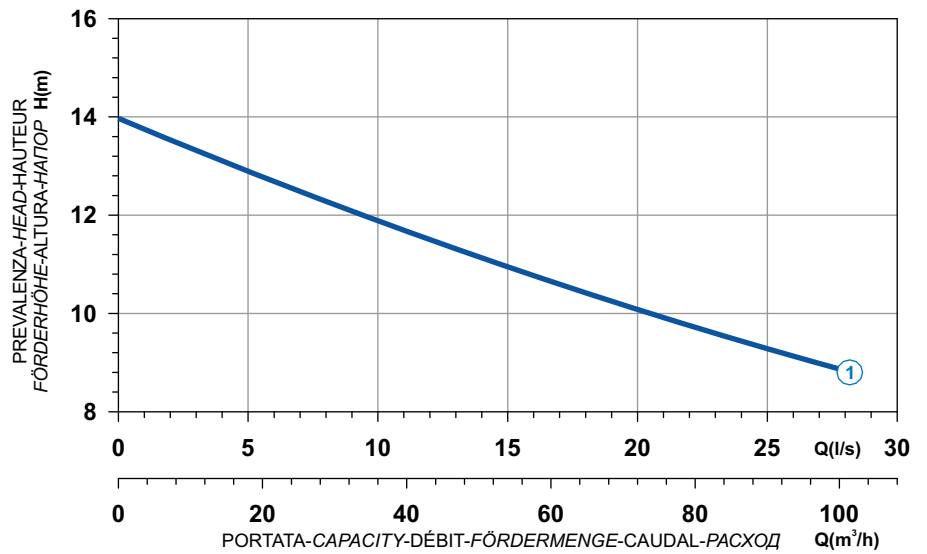



Power supply	3ph 400/690V 50Hz
R.P.M.	1450
Free passage (mm)	50
Discharge (mm)	DN 100
Max Weight (Kg)	91

Curve N°	Code	Type	MOTOR			ATEX code
			Rated power P2 (kW)	Rated current I (A)	Starting current Is (A)	
1	7008259	G410R2H1-P50AA2	4,6	9,3	46,5	7009192

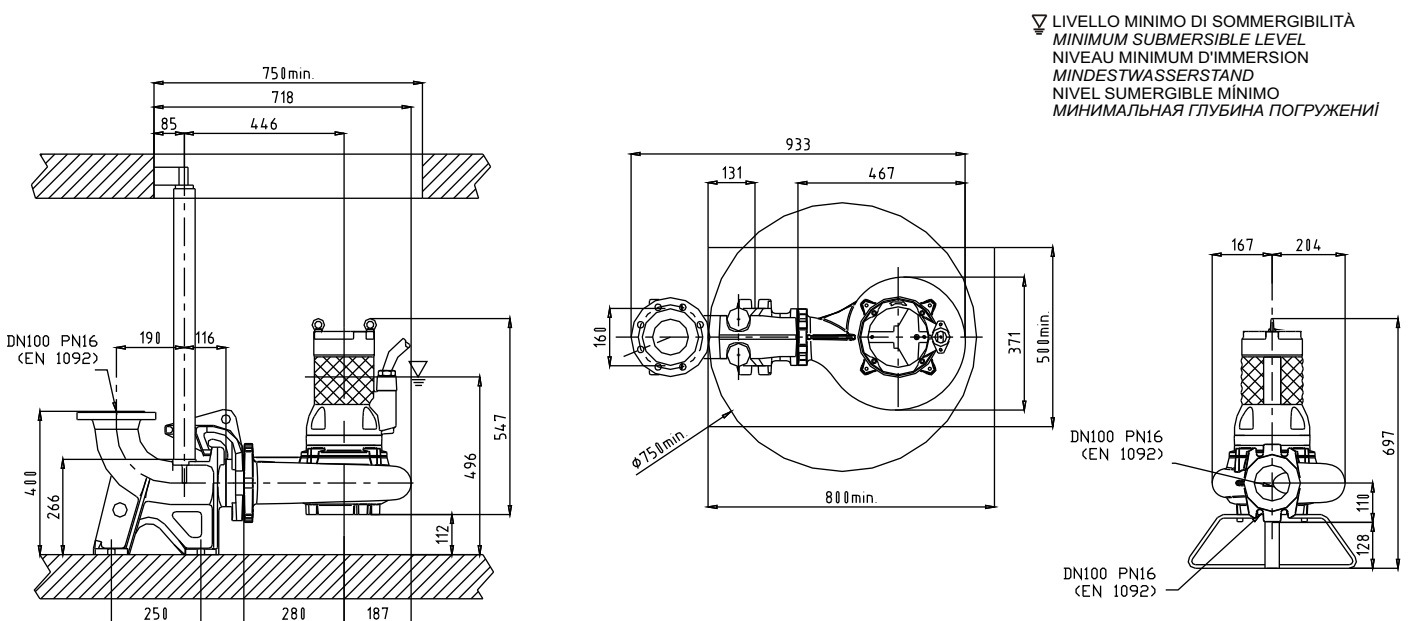
## Dimensioni - Dimensions - Dimensions - Abmessungen - Dimensiones - Габариты (mm)



 Ghisa EN-GJL-250  
 Fonte EN-GJL-250  
 Hierro fundido EN-GJL-250

 Cast Iron EN-GJL-250  
 Grauguss EN-GJL-250  
 Чугун EN-GJL-250

**Curva caratteristica - Performance curve - Courbe caractéristique**  
**Kennlinie - Curva característica - Характеристическая кривая**

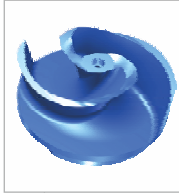
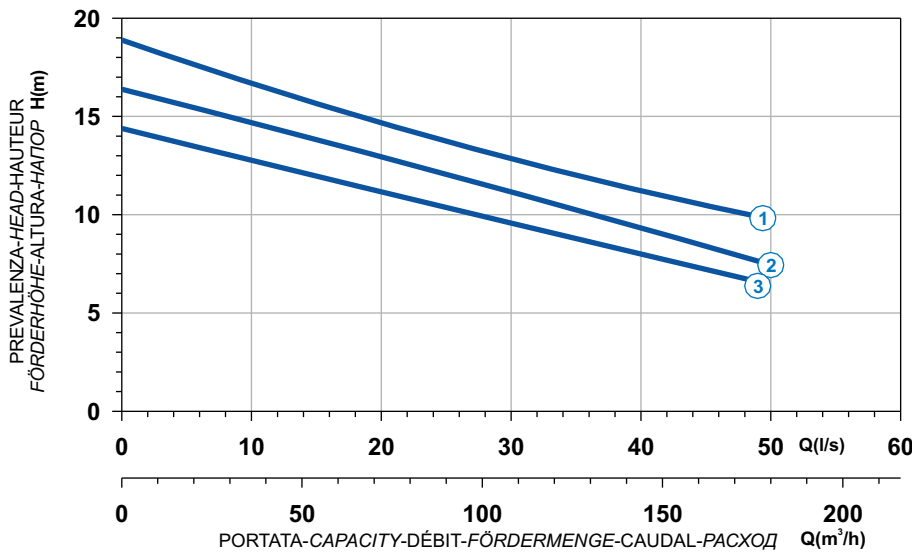

H

Curve N°	Code	Type	MOTOR			ATEX code 
			Rated power P2 (kW)	Rated current I (A)	Starting current Is (A)	
1	7008105	G411R2H1-P60AA2	8,5	16,2	95,6	7008856
2	7007261	G411R2H2-P60AA2	7,1	13,5	79,6	7007262
3	7005122	G411R2H3-P60AA2	7,1	13,5	79,6	7008951

Power supply	3ph 400/690V 50Hz
R.P.M.	1450
Free passage (mm)	60
Discharge (mm)	DN 100
Max Weight (Kg)	185

**Dimensioni - Dimensions - Dimensions - Abmessungen - Dimensiones - Габариты (mm)**

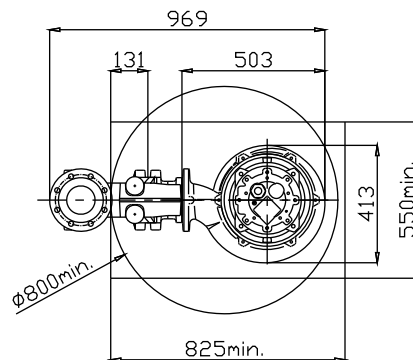
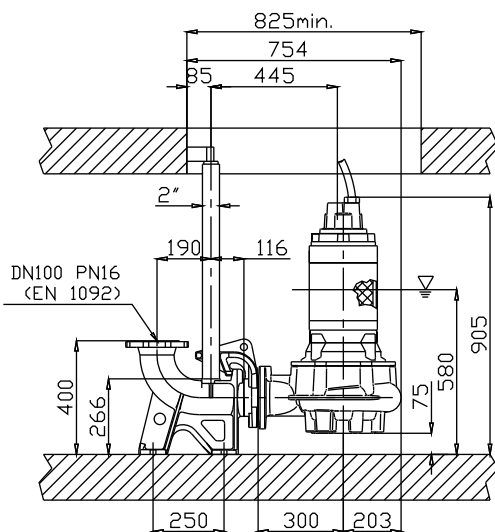

▽ LIVELLO MINIMO DI SOMMERGIBILITÀ  
 MINIMUM SUBMERSIBLE LEVEL  
 NIVEAU MINIMUM D'IMMERSION  
 MINDESTWASSERSTAND  
 NIVEL SUMERGIBLE MÍNIMO  
 МИНИМАЛЬНАЯ ГЛУБИНА ПОГРУЖЕНИЯ

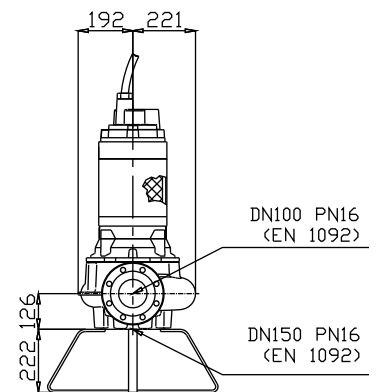

Versione disponibile con mantello di raffreddamento - Type available also with cooling jacket  
 Version disponible avec chemise de refroidissement - Ausführung auch mit Kühlmantel lieferbar  
 Disponible también con camisa de refrigeración - Вариант доступен с рубашкой охлаждения

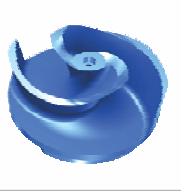

Ghisa EN-GJL-250

Fonte EN-GJL-250

Hierro fundido EN-GJL-250

Cast Iron EN-GJL-250

Grauguss EN-GJL-250

Чугун EN-GJL-250

Curva caratteristica - Performance curve - Courbe caractéristique  
Kennlinie - Curva característica - Характеристическая кривая

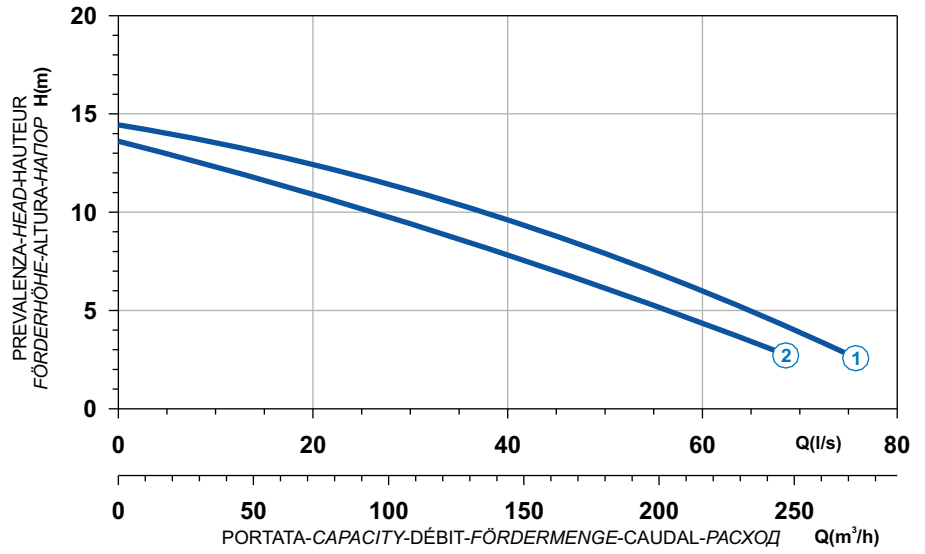

Power supply	3ph 400/690V 50Hz
R.P.M.	1450
Free passage (mm)	60
Discharge (mm)	DN 150
Max Weight (Kg)	200



Curve N°	Code	Type	MOTOR			ATEX code
			Rated power P2 (kW)	Rated current I (A)	Starting current Is (A)	
1	7005270	G411R2H1-S60AA2	7,1	13,5	79,7	7006273
2	7009487	G411R2H3-S60AA2	7,1	13,5	79,7	7005230

## Dimensioni - Dimensions - Dimensions - Abmessungen - Dimensiones - Габариты (mm)

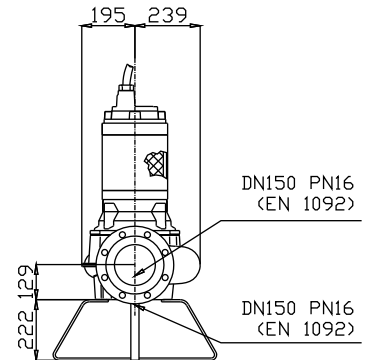
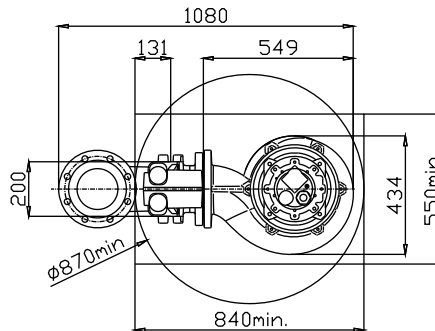
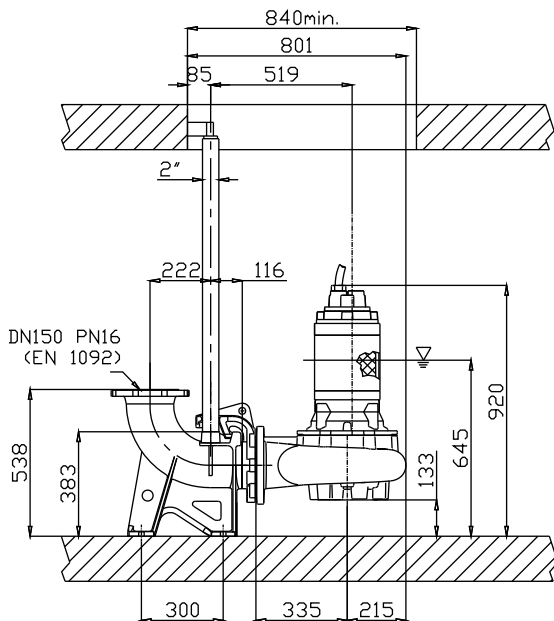
▽ LIVELLO MINIMO DI SOMMERGIBILITÀ  
MINIMUM SUBMERSIBLE LEVEL  
NIVEAU MINIMUM D'IMMERSION  
MINDESTWASSERSTAND  
NIVEL SUMERGIBLE MÍNIMO  
МИНИМАЛЬНАЯ ГЛУБИНА ПОГРУЖЕНИЯ



Versione disponibile con mantello di raffreddamento - Type available also with cooling jacket  
Version disponible avec chemise de refroidissement - Ausführung auch mit Kühlmantel lieferbar  
Disponible también con camisa de refrigeración - Вариант доступен с рубашкой охлаждения

 Ghisa EN-GJL-250  
 Fonte EN-GJL-250  
 Hierro fundido EN-GJL-250

 Cast Iron EN-GJL-250  
 Grauguss EN-GJL-250  
 Чугун EN-GJL-250

Curva caratteristica - Performance curve - Courbe caractéristique  
 Kennlinie - Curva característica - Характеристическая кривая

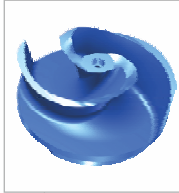
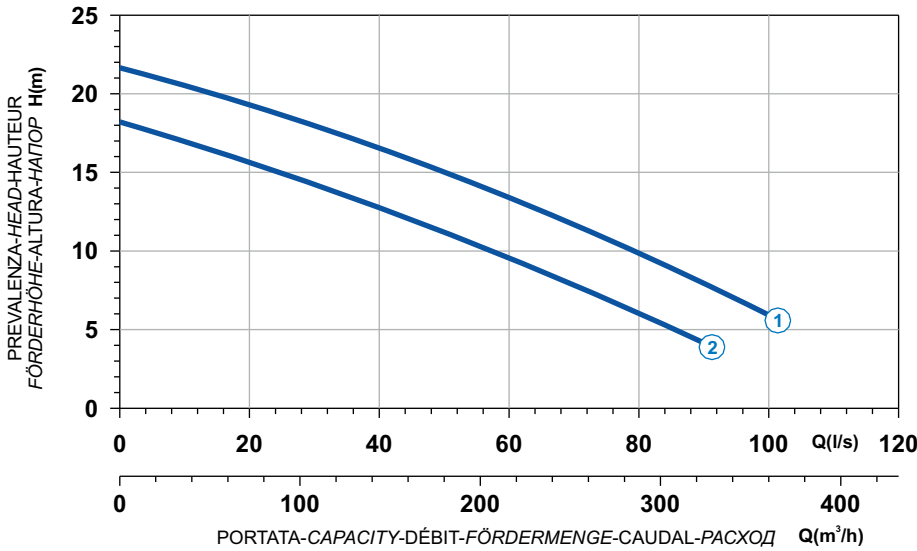

H

Curve N°	Code	Type	MOTOR			ATEX code 
			Rated power P2 (kW)	Rated current I (A)	Starting current Is (A)	
1	7008440	G413R2H1-S60AA2	14,4	26,7	158	7006277
2	7003588	G413R2H4-S60AA2	10	19	112	7007251

Power supply	3ph 400/690V 50Hz
R.P.M.	1450
Free passage (mm)	60
Discharge (mm)	DN 150
Max Weight (Kg)	244

### Dimensioni - Dimensions - Dimensions - Abmessungen - Dimensiones - Габариты (mm)

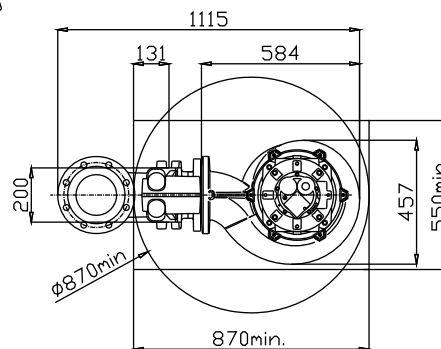
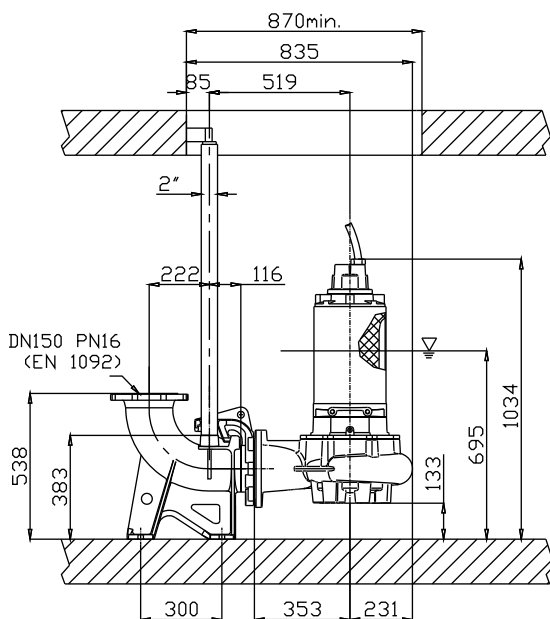

▽ LIVELLO MINIMO DI SOMMERSIBILITÀ  
 MINIMUM SUBMERSIBLE LEVEL  
 NIVEAU MINIMUM D'IMMERSION  
 MINDESTWASSERSTAND  
 NIVEL SUMERGIBLE MÍNIMO  
 МИНИМАЛЬНАЯ ГЛУБИНА ПОГРУЖЕНИЯ

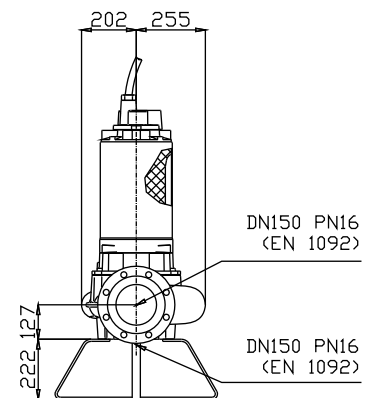

Versione disponibile con mantello di raffreddamento - Type available also with cooling jacket  
 Version disponible avec chemise de refroidissement - Ausführung auch mit Kühlmantel lieferbar  
 Disponible también con camisa de refrigeración - Вариант доступен с рубашкой охлаждения



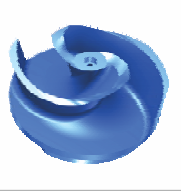

Ghisa EN-GJL-250

Fonte EN-GJL-250

Hierro fundido EN-GJL-250

Cast Iron EN-GJL-250

Grauguss EN-GJL-250

Чугун EN-GJL-250

Curva caratteristica - Performance curve - Courbe caractéristique  
Kennlinie - Curva característica - Характеристическая кривая

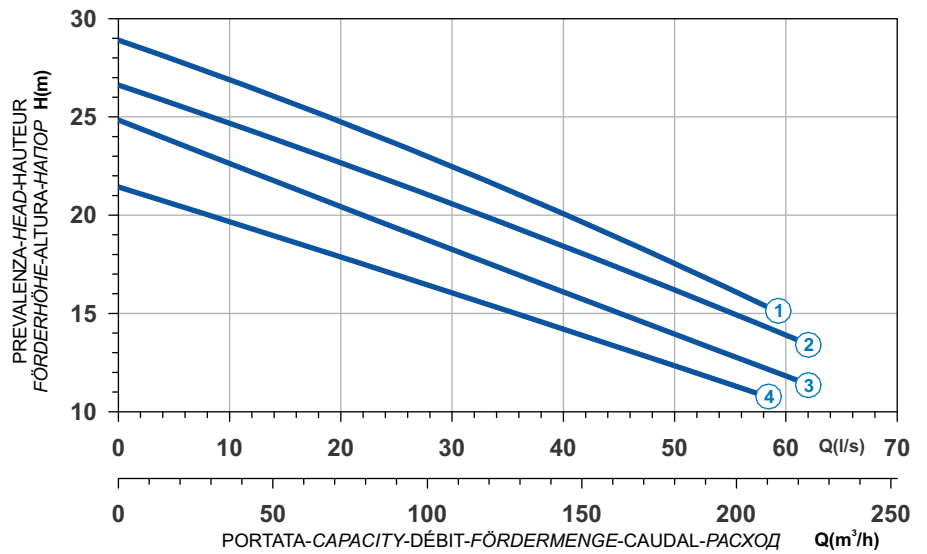

Power supply	3ph 400/690V 50Hz
R.P.M.	1450
Free passage (mm)	60
Discharge (mm)	DN 100
Max Weight (Kg)	235

Curve N°	Code	Type	MOTOR			ATEX code
			Rated power P2 (kW)	Rated current I (A)	Starting current Is (A)	
1	7009023	G413R2H1-P60AA2	17	31,5	186	7005903
2	7005809	G413R2H2-P60AA2	16	29,7	175	7005904
3	7001899	G413R2H3-P60AA2	14,4	26,7	157	7005905
4	7008041	G413R2H4-P60AA2	11,6	21,6	127	7007664

## Dimensioni - Dimensions - Dimensions - Abmessungen - Dimensiones - Габариты (mm)

▽ LIVELLO MINIMO DI SOMMERGIBILITÀ  
MINIMUM SUBMERSIBLE LEVEL  
NIVEAU MINIMUM D'IMMERSION  
MINDESTWASSERSTAND  
NIVEL SUMERGIBLE MINIMO  
МИНИМАЛЬНАЯ ГЛУБИНА ПОГРУЖЕНИЯ

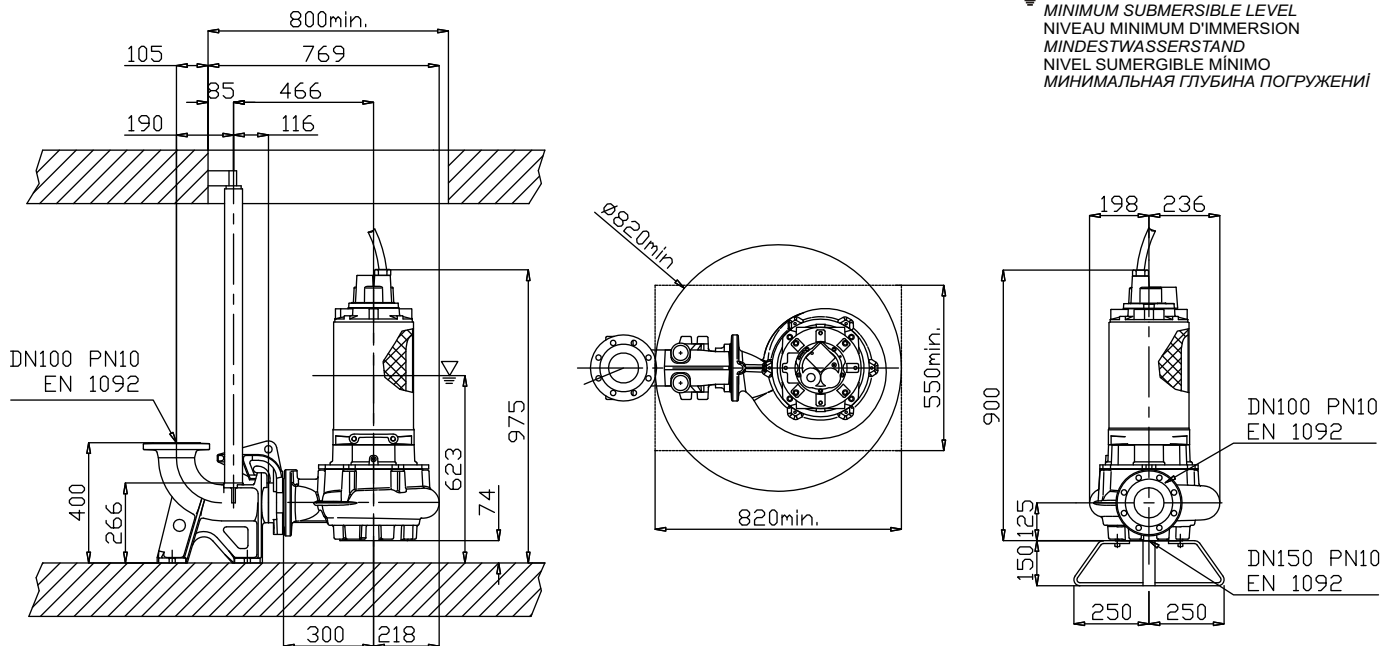

**Installazione a secco**  
**Dry pit installation**  
**Installation fixe en chambre sèche**  
**Trockenaufstellung**  
**Instalación fija en cámara aislada**  
**Сухая установка**

**G211R2H1-M30AM2**  
**G211R2H2-M30AM2**  
**G211R2H3-M30AM2**

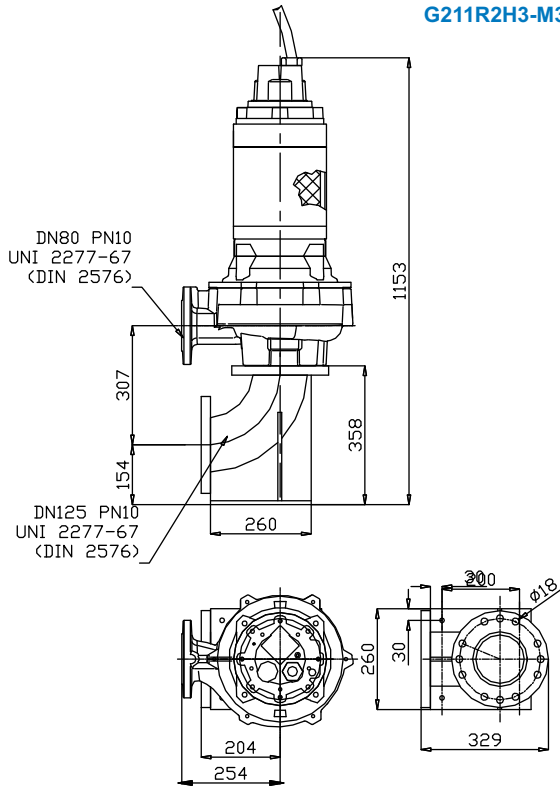

**G216R2H1-P40KM2**  
**G216R2H2-P40KM2**  
**G216R2H3-P40KM2**  
**G218R2H2-P40KM2**  
**G218R2H4-P40KM2**

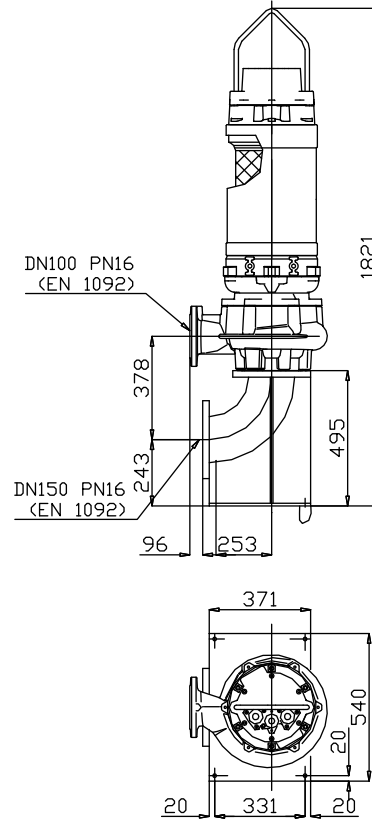

**G411R2H1-P60AM2**  
**G411R2H2-P60AM2**  
**G411R2H3-P60AM2**  
**G413R2H1-P60AM2**  
**G413R2H2-P60AM2**  
**G413R2H3-P60AM2**  
**G413R2H4-P60AM2**

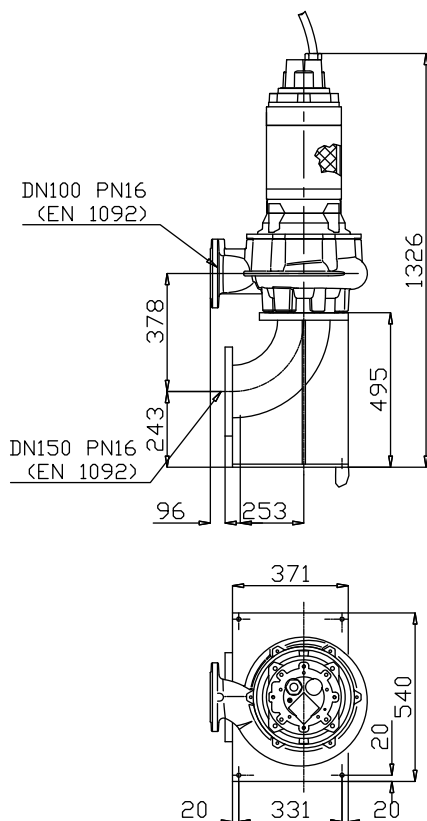

**G411R2H1-S60AM2**  
**G411R2H3-S60AM2**  
**G413R2H1-S60AM2**  
**G413R2H4-S60AM2**

