



Italian Vacuum Compressors

CLAW PUMPS - VACUUM & COMPRESSORS

Manufacturing Partner for:



Please contact us:
sales@a3-usa.com
412.849.6136

ICV- B SERIES Claw Vacuum Pumps



ICV- 60, 100



Dry Running - Oil Free – Contact Free Design

- **Simple Modular Construction**
- **Air cooled & Direct Driven**
- **Low maintenance – No wear**
- **High Efficiency – Continuous Duty**

Applications:

Packaging, CNC Routing, Wood Works, Pneumatic Conveying, Holding & Lifting, Pick and Place, Medical & Lab., Plastics Industries, Central Vacuum Systems.

Safety: CE certified (DOC) 

General Description:

The ICV-B Series pumps are dry contact-less vacuum pumps with modular constructions consisting of compartments: pumping and gear chambers are separated by using labyrinth seals. As two claws rotate in opposite direction, the air will be sucked in the pumping chamber, compressed and discharged under pressure. In gear chamber, two gears for synchronizing of claws rotation will be placed with appropriate oil lubrication. A built in anti-suck back valve installed in inlet flange will prevent the air from flowing back into the vacuum chamber when the pump is shutdown. The pumps are directly driven by a flanged motor via a coupling.

Specifications:

Model		ICV 60	ICV 100
M3/ Hour	60Hz	72	120
	50Hz	60	100
Ulti. Va. Max.	Torr	722 Torr gage (50mbar abs)	
Ulti. Va. Conti.	Torr	685	640
Kw	60Hz	1.5	2.6
	50Hz	1.1	2.2
RPM	60/50Hz	3450/2850	
Voltage Available		208~230/460V, 220~240 /380~420V, 400/690V	
dB(A), Average	60Hz	80	77
	50Hz	78	76
Oil Capa (Gear box)	Ltr	0.6	0.75
Inlet / Outlet Conn.	**BSP(G)	1"	1-1/2"
L* x W x H (mm)	60Hz	758x321x461	720x548x399
	50Hz	736x321x461	709x548x399
Amb. Operating Temp.	(°C)	5°C ~40°C	
Approx. *Weight (Kg).	60Hz	60	111
	50Hz	55	106
Accessories		Non Return Valve, Vacuum Regulator, Exhaust Silencer	

Note: 1) * Length varies to motor mfg 2) **NPT threads available upon request

ICV- B SERIES Claw Vacuum Pumps



ICV- 60, 100

Performance Curve

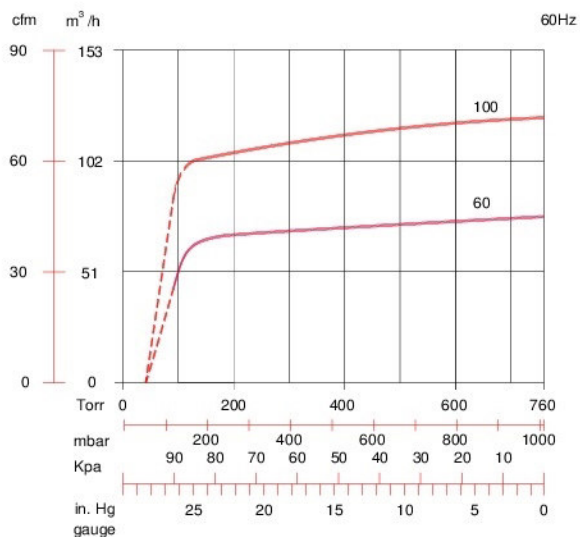
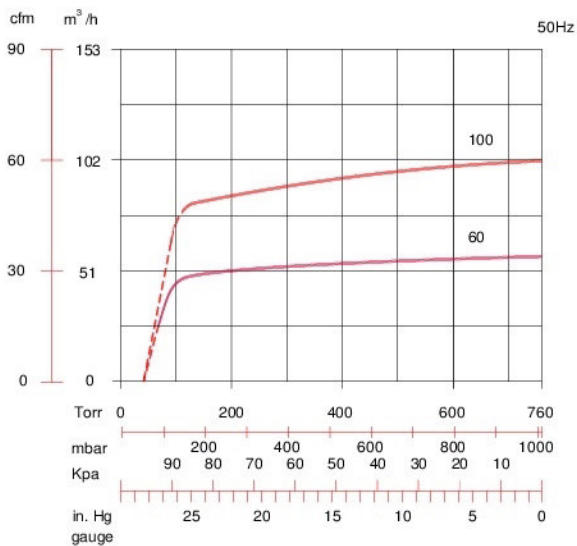

Dimensions

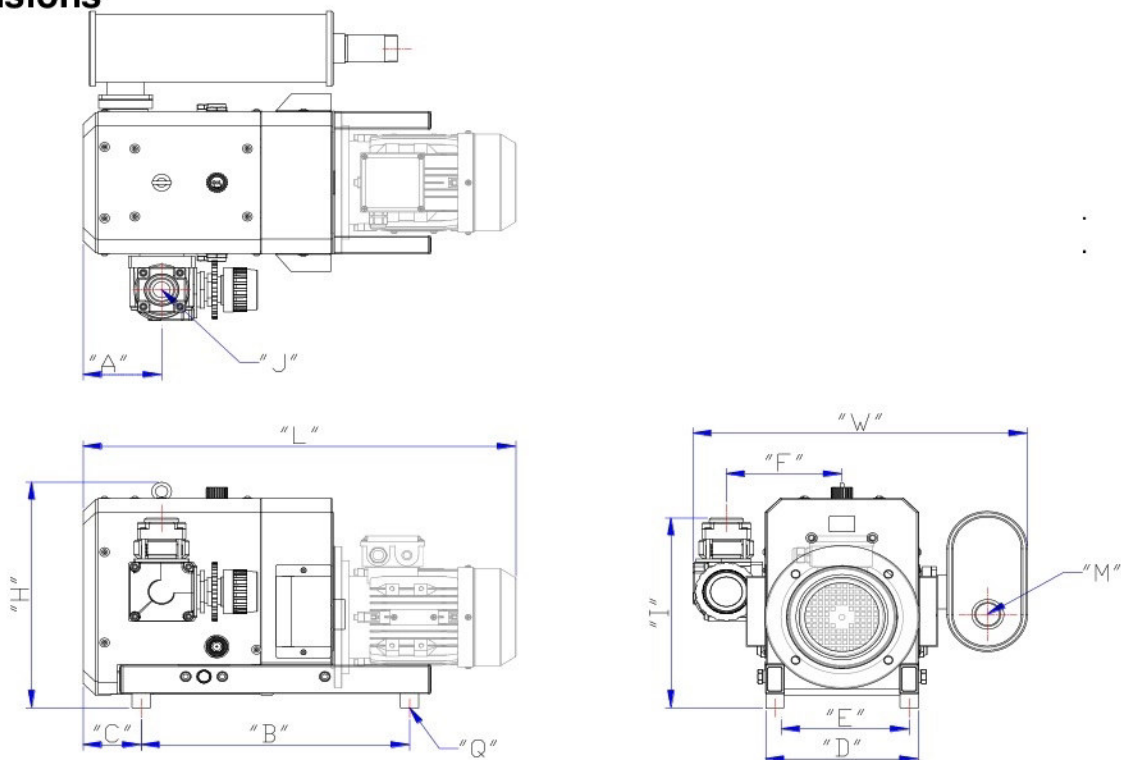

DIMENSIONS	L	W	H	B	C	E	D	F	A	I	J	M	Q
ICV -60 (1.1, 1.5Kw)	736/758	321	461	247	194	144	174	120	162	235	1"	1"	4x M8
ICV -100 (2.2, 3Kw)	709/720	548	399	440	98	224	254	201	128	334	1-1/2"	1-1/2"	4x M8

ICV SERIES Claw Vacuum Pumps



ICV- 155, 255, 305, 405 & 515



Dry Running - Oil Free – Contact Free Design

- **Simple Modular Construction**
- **Air cooled & Direct Driven**
- **Low maintenance – No wear**
- **High Efficiency – Continuous Duty**

Applications:

Packaging, CNC Routing, Wood Works, Pneumatic Conveying, Holding & Lifting, Pick and Place, Medical & Lab., Plastics Industries, Central Vacuum Systems.

Safety: CE certified (DOC)



General Description:

The ICV Series pumps are dry contact-less vacuum pumps with modular constructions consisting of compartments: pumping and gear chambers are separated by using labyrinth seals., As two claws rotate in opposite direction, the air will be sucked in the pumping chamber, compressed and discharged under pressure. In gear chamber, two gears for synchronizing of claws rotation will be placed with appropriate oil lubrication. A built in anti-suck back valve installed in inlet flange will prevent the air from flowing back into the vacuum chamber when the pump is shutdown. The pumps are directly driven by a flanged motor via a coupling.

Specifications:

Model		ICV 155	ICV 255	ICV 305	ICV 405	ICV 515
M3/ Hour	60Hz	180	300	360	480	600
	50Hz	150	250	300	400	500
Ulti. Va. Max.	Torr	722.5 Torr gage (50mbar abs)				
Ulti. Va. Conti.	Torr	647.5	610			
Kw	60Hz	3.4	5.5	6.6	9	11
	50Hz	2.8	4.3	5.5	7.5	9
RPM (motor)	60/50Hz	3450 / 2850				
Voltage Available		208~230/460V, 220~240 / 380~420V, 400/690V				
dB(A), Max +- 3 tolerance	60Hz	77	80	80	80	82
	50Hz	73	78	78	78	80
Oil Capa (Gear box)	Ltr	0.5	0.9		1.8	
Inlet / Outlet Conn.	**BSP(G)	1-1/2"	2"		3"	
W x H (mm)		422 x 562	501 x 685	501 x 685	586 x 695	586 x 695
L* (mm)	60Hz	862	961	975	1105	1291
	50Hz	837	961	975	1065	1120
Amb. Operating Temp.	(°C)	5°C ~40°C				
Accessories		Non Return Valve, Vacuum Regulator, Exhaust Silencer				

Note: 1) * Length varies to motor mfg 2) **NPT threads available upon request

ICV SERIES Claw Vacuum Pumps



ICV- 155, 255, 305, 405 & 515

Dimensions

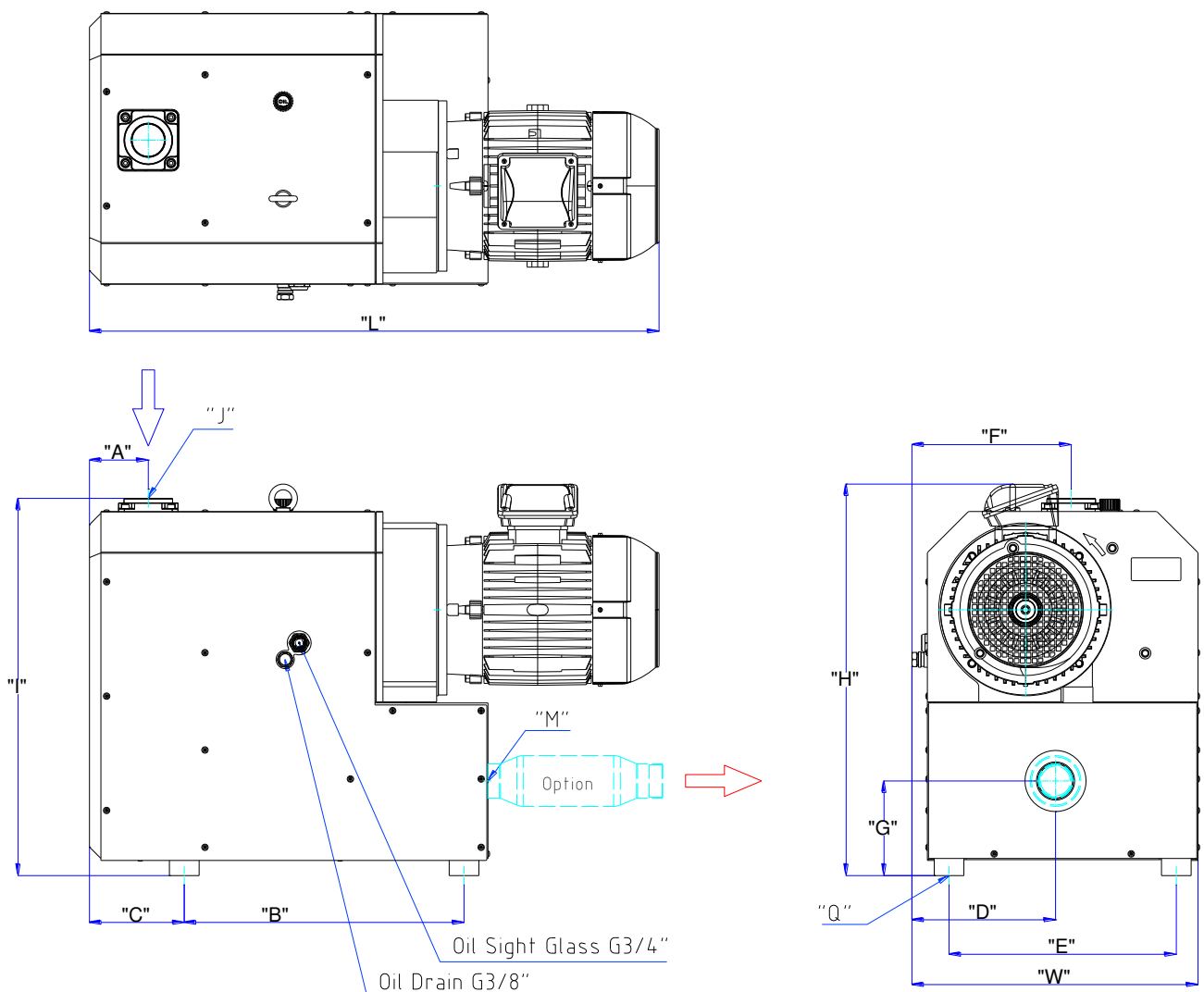

Dimensions (mm)		L	W	H	A	B	C	D	E	F	G	I	J	M	Q
ICV-155	3Kw / 4Kw	837 / 862	435	562	136	380	113	227	356	253	139	562	1-1/2"	1-1/2"	M10 Tap
ICV-255	4.5Kw, 5.5Kw	961	501	685	103	490	166	252	398	279	166	660	2"	2"	M10 Tap
ICV-305	5.5Kw, 7.5Kw	975	501	685	103	490	180	252	398	279	166	660	2"	2"	M10 Tap
ICV-405	7.5Kw / 9.2Kw	1065 / 1105	856	752	179	502	222	306	460	390	178	695	3"	3"	M12 Tap
ICV-515	9.2Kw / 11Kw	1120 / 1290	586	752	179	502	238	306	460	390	178	695	3"	3"	M12 Tap

ICV SERIES Claw Vacuum Pumps



ICV- 155, 255, 305, 405 & 515

Performance Curve

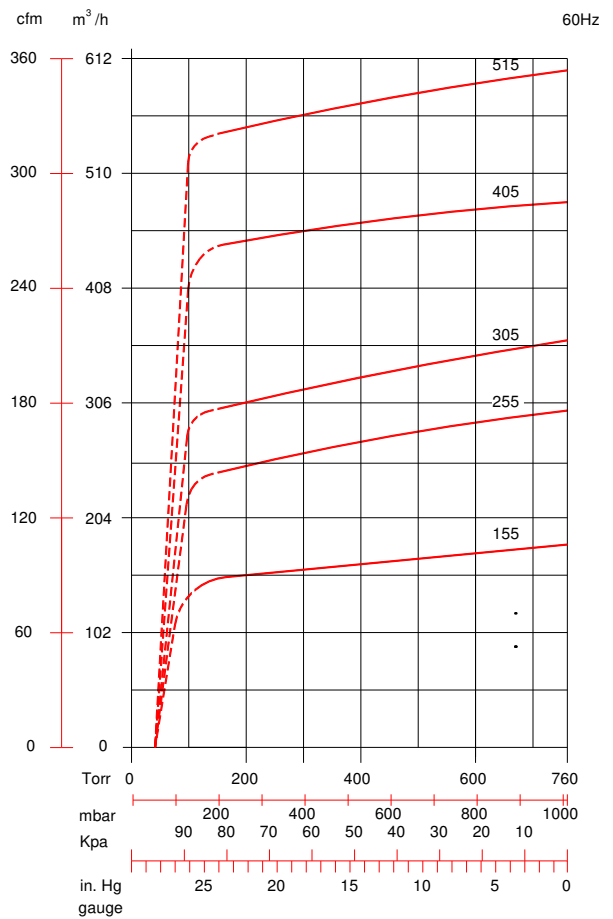
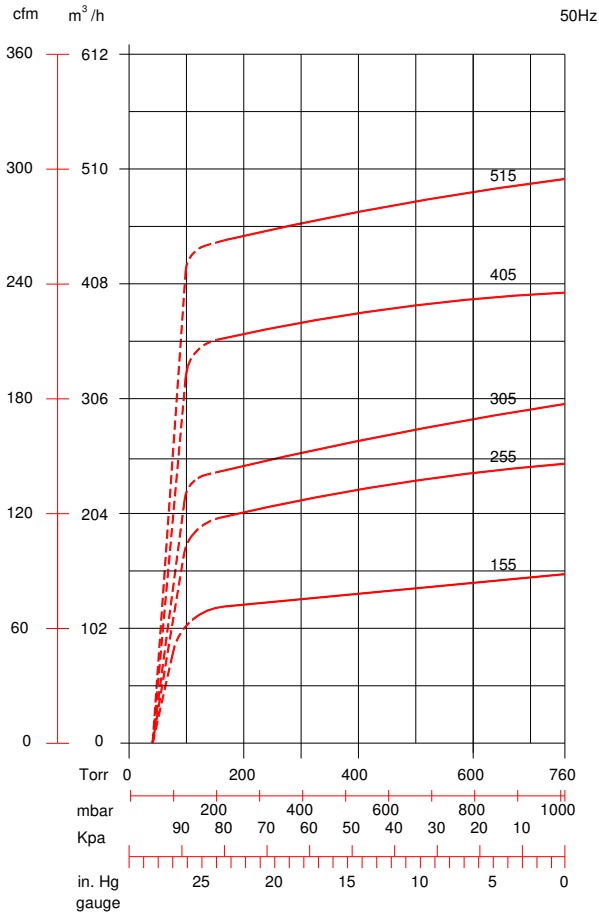

**ICV
SERIES
Claw Vacuum Pumps
ICV - 1005**



Dry Running - Oil Free – Contact Free Design

- **Simple Modular Construction**
- **Air cooled & Direct Driven**
- **Low maintenance – No wear**
- **High Efficiency – Continuous Duty**

Applications:

Packaging, CNC Routing, Wood Works, Pneumatic Conveying, Holding & Lifting, Pick and Place, Medical & Lab., Plastics Industries, Industrial Central Vacuum Systems.

CE certified



General Description:

The ICV Series pumps are dry contact-less vacuum pumps with modular constructions consisting of compartments: pumping and gear chambers are separated by using labyrinth seals. As two claws rotate in opposite direction, the air will be sucked in the pumping chamber, compressed and discharged under pressure. In gear chamber, two gears for synchronizing of claws rotation will be placed with appropriate oil lubrication. The pumps are directly driven by a flanged motor via a coupling. Configured with two silencers suitable for compact installation space. The 4" aluminum check valve for anti suck back and inlet filter (flanged) can be supplied separately. Ideally suited to use with Frequency Controlled Drives for energy saving.

Specifications:

Model		ICV 1005
M3 / Hour (cfm)	60Hz	1140 (670cfm)
	50Hz	950 (558cfm)
Ultimate Va. Max.	Torr (mbar a)	722.5 (50mbar a)
Ultimate Va. Continuous	Torr	610 (200mbar a)
Kw(Hp)	60Hz	22 (30Hp)
	50Hz	18.5 (25Hp)
RPM	60/50Hz	3450/2850
Voltage Available		220~240/380~420V x 50/60Hz, 400/690Vx 50Hz, 208~230/460V x 60Hz
dB(A), Max +- 3 tolerance	60Hz	85
	50Hz	82
Oil Capacity (Gear box)	Ltr	2.8
Inlet / Outlet Connection	Flange	DN 100 PN6 / DN100 PN10
Amb. Operating Temp.	(°C)	5~40
Accessories	Non Return Valve, Vacuum Regulator, Exhaust Silencer	

ICV-1005 Dimensions

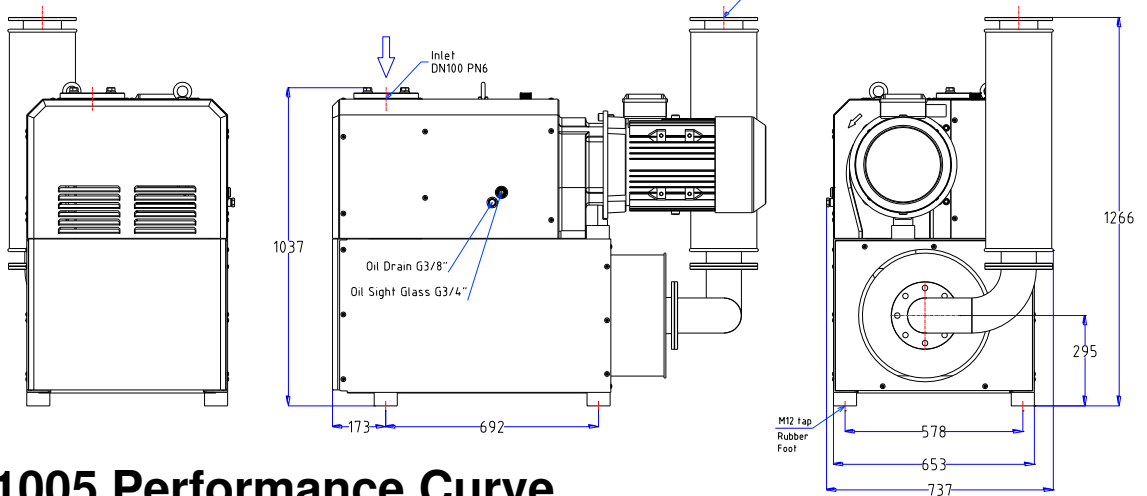
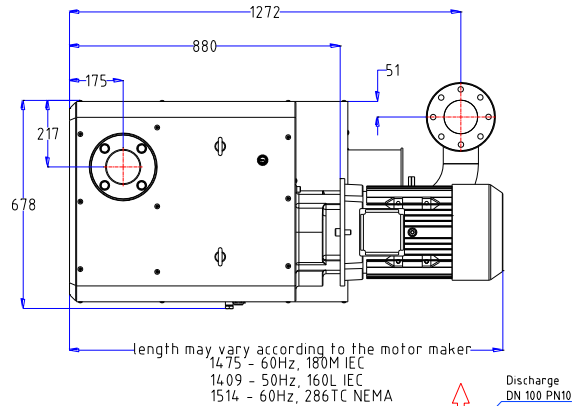

ICV-1005 Performance Curve

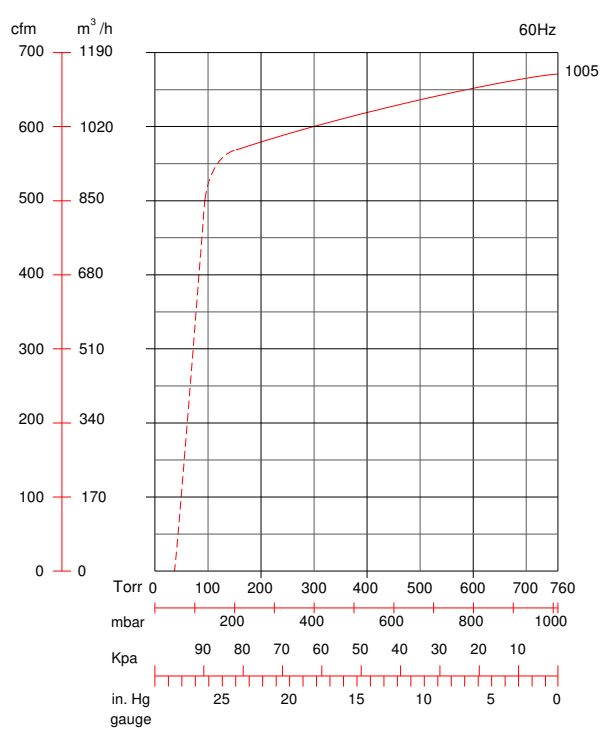
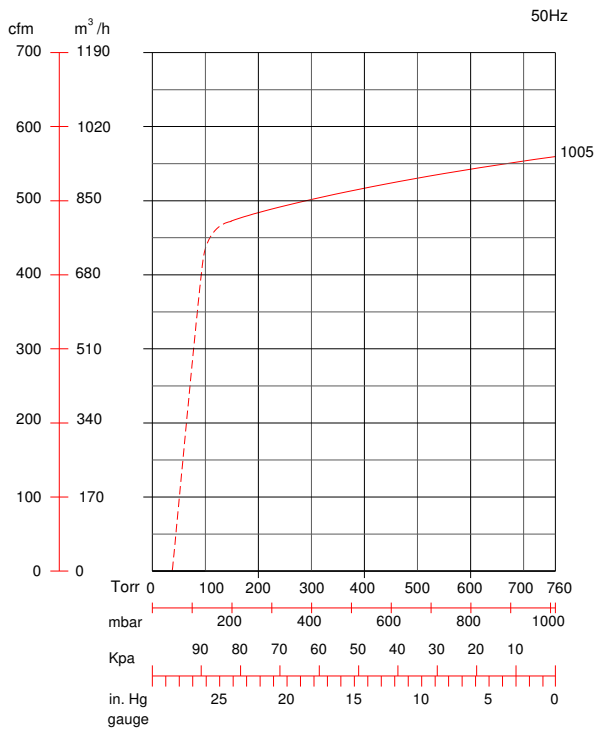

ICP SERIES Claw Compressors



ICP- 60, 100



Dry Running - Oil Free – Contact Free Design

- **Simple Modular Construction**
- **Air cooled & Direct Driven**
- **Low maintenance – No wear**
- **High Efficiency – Continuous Duty**

Applications:

Transport, Pneumatic Conveying, Environmental systems, Air Sparging Applications, Fishing Farm, Central Pressure System.

Safety: CE certified (DOC)



General Description:

The ICP Series compressors are identical in internal construction to VCX pump, but are outfitted with different inlet and outlet accessories to allow for operation as a compressor. For reduction of noise, inlet silencer is installed in inlet side. For a protection of overload, a pressure safety valve or regulating valve is installed in exhaust side. The compressors are directly driven by a flanged motor via a coupling.

Specifications:

Model		ICP 60	ICP 100		
M3/ Hour	60Hz	68	120		
	50Hz	56	100		
Press. Conti., Bar	60Hz	2	~	1.4	2.2
	50Hz	2	0.8	1.4	2.2
Kw	60Hz	3.6	~	4.8	6.5
	50Hz	3	3	4	5.5
RPM - 60/50Hz	RPM	3450 / 2850			
Voltage, Available	V	208~230/460V, 220~240 / 380~420V, 400/690V			
dB(A), Max	60Hz	79	83		
+ - 3 tolerance	50Hz	78	81		
Oil Capa (Gear box)	Ltr	0.6	0.75		
Inlet / Outlet Conn.	**BSP(G)	1"	1-1/2"		
W x H (mm)		297X461	488 x 618/673^ (5.5kw+)		
L* (mm)	60Hz	806	-	778	778
	50Hz	781	717	742	778
Amb. Operating Temp	(°C)	5°C ~40°C			
Approx. *Weight (Kg).	60Hz	75	~	135	150
	50Hz	69	108	120	140
Accessories		Pressure Regulator, Safety Valve, Inlet Silencer, and Inlet Filter			

Note: 1) * Length varies to motor mfg 2) **NPT threads available upon request

ICP SERIES Claw Compressors

ICP- 60, 100

Performance Curve

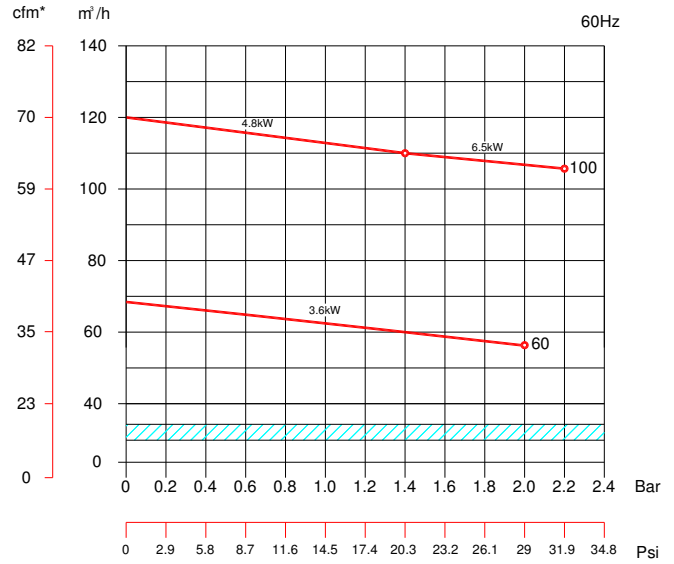
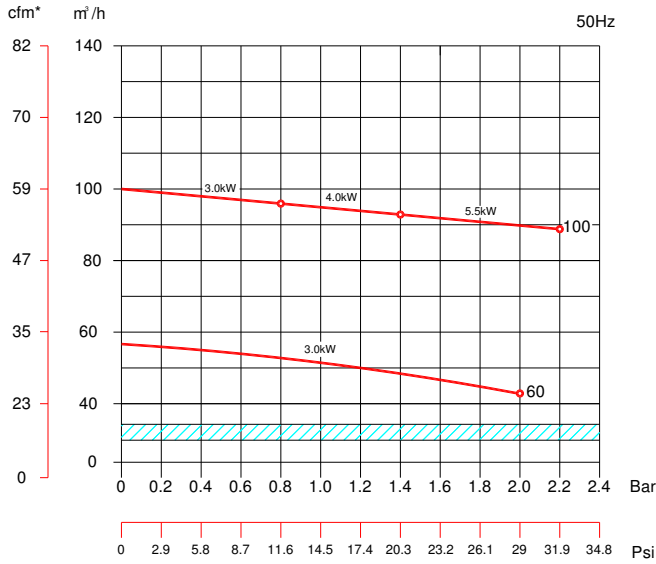

Dimensions

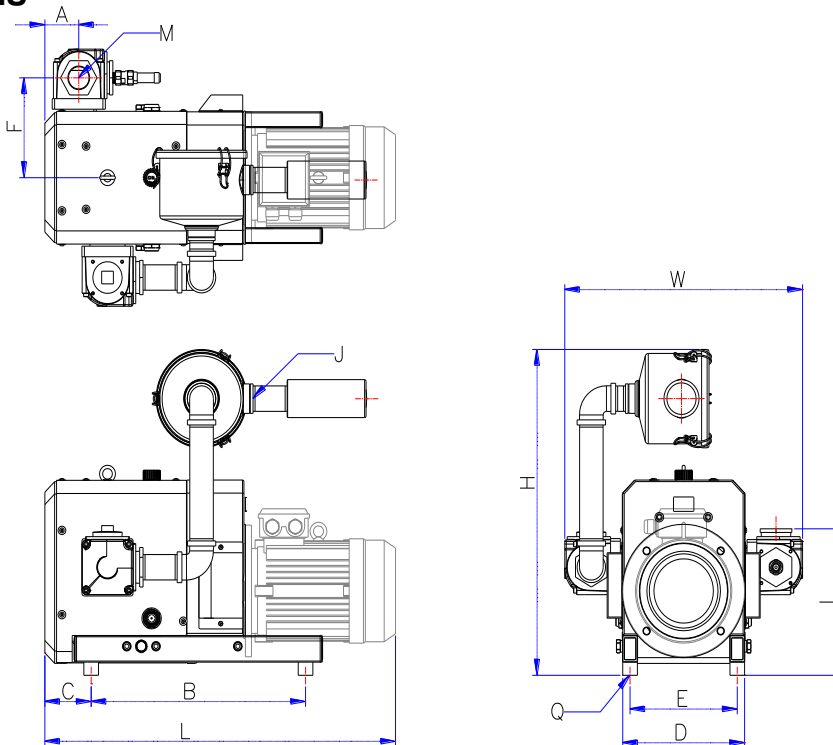

DIMENSIONS	L	W	H	B	C	E	D	F	A	I	J	M	Q
PCX-60, (3, 3.6kw)	781/806	297	461	278	96	144	174	23	83	164	1-1/4"	1"	4XM8
PCX-100, (3, 4, ~4.8~6.5kw)	717/742/~778	488	618/~673	440/~640	97	220	270	190	69	283/~333	1-1/2"	1-1/2"	4XM10

ICP SERIES Claw Compressors



ICP- 155, 255, 305, 405 & 515

Dry Running - Oil Free – Contact Free Design



- **Simple Modular Construction**
- **Air cooled & Direct Driven**
- **Low maintenance – No wear**
- **High Efficiency – Continuous Duty**

Applications:

Transport, Pneumatic Conveying, Environmental systems, Air Sparging Applications, Fishing Farm, Central Pressure System.

Safety: CE certified (DOC)



General Description:

The ICP Series compressors are identical in internal construction to VCX pump, but are outfitted with different inlet and outlet accessories to allow for operation as a compressor. For reduction of noise, inlet silencer is installed in inlet side. For a protection of overload, a pressure safety valve or regulating valve is installed in exhaust side. The compressors are directly driven by a flanged motor via a coupling.

Specifications:

Model		ICP 155				ICP 255				ICP 305				ICP 405				ICP 515			
M3/ Hour	60Hz	180				300				360				480				600			
	50Hz	150				250				300				400				500			
Press. Conti., Bar	60Hz	1	2	0.8	1.4	1.8	2.2	~	1.2	2.2	0.6	1.2	1.6	2	0.8	-	1.6	2			
	50Hz	1	2	1	~	2	~	0.6	1.4	2.2	0.8	1.4	1.8	2	0.8	1.2	1.6	2			
Kw	60Hz	6.5	9	9	11	13	15	~	13	18	13	18	22	26	18	-	26	36			
	50Hz	6.5	7.5	7.5	~	11	~	7.5	11	15	11	15	18.5	22	15	18.5	22	30			
RPM - 60/50Hz	RPM	3450 / 2850																			
Voltage, Available	V	208~230/460V, 220~240 / 380~420V, 400/690V																			
dB(A), Ave	60Hz	82				82				82				83				83			
	50Hz	80				79				79				81				81			
Oil Capa (Gear box)	Ltr	0.5				0.9								1.8							
Inlet / Outlet Conn.	**BSP(G)	1-1/2"				2"								3"							
W x H (mm)		431 x 403				573 x 757				573 x 757				672 x 1003				672 x 1003			
L* (mm)	60Hz	903	941	1001	1171	1171	1171	~	1183	1183	1274	1274	1340	1395	1289	~	1410	1410			
	50Hz	903	903	961	~	1171	~	973	1183	1183	1274	1274	1274	1340	1289	1289	1355	1410			
Amb. Operating Temp	(°C)	5°C ~40°C																			
Accessories		Pressure Regulator, Safety Valve, Inlet Silencer, and Inlet Filter																			

Note: 1) * Length varies to motor mfg 2) **NPT threads available upon request

ICP SERIES Claw Compressors



ICP- 155, 255, 305, 405 & 515

Dimensions

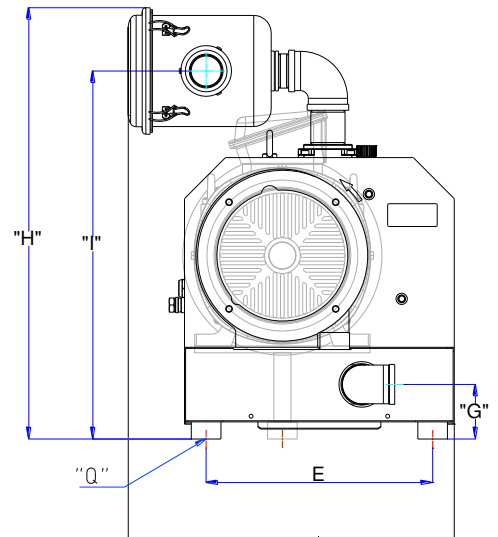
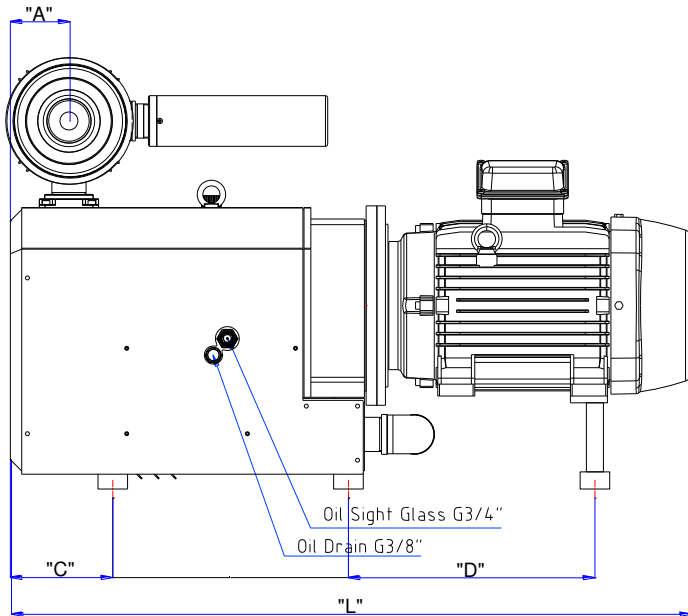
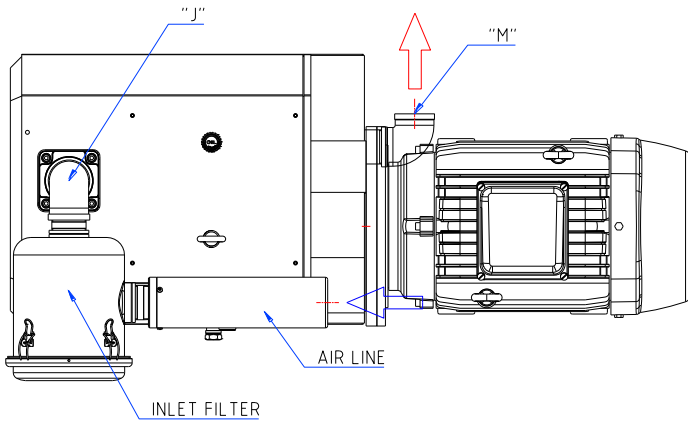

Dimensions (mm)		L	W	H	A	B	C	D	E	G	I	J	M	Q
ICP-155	5.5Kw, 6.5Kw, 7.5Kw / 9.2Kw	903 / 941	431	643	136	380	113	556	356	89	550	1-1/2"	1-1/2"	M10 Tap
ICP-255	7.5Kw / 9.2Kw / 11Kw, 15Kw	961 / 1001 / 1171	573	757	103	490	166	/ / 379	398	96	646	2"	2"	M10 Tap
ICP-305	7.5Kw / 11Kw, 15Kw, 18.5Kw	973 / 1183	573	757	103	490	180	/ / 379	398	96	646	2"	2"	M10 Tap
ICP-405	11Kw, 15Kw, 18.5Kw / 22Kw / 30Kw	1274 / 1340 / 1394	672	1003	179	502	222	/ 346 / 514	460	138	753	3"	3"	M12 Tap
ICP-515	15Kw, 18.5Kw / 22Kw / 30Kw, 37Kw	1289 / 1355 / 1410	672	1003	179	502	238	/ 346 / 514	460	138	753	3"	3"	M12 Tap

ICP SERIES Claw Compressors



ICP- 155, 255, 305, 405 & 515

Performance Curve – 155

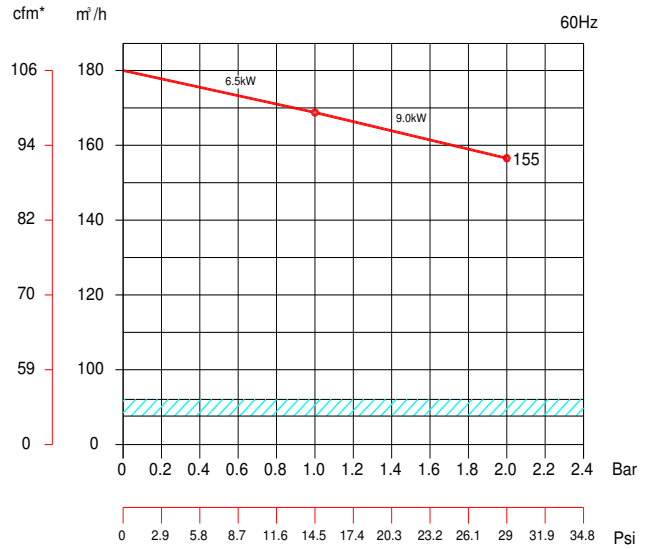
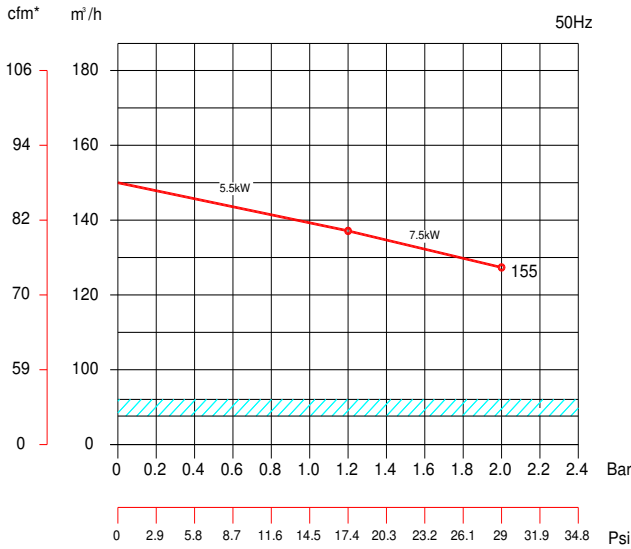

Performance Curve – 255, 305, 405, & 515

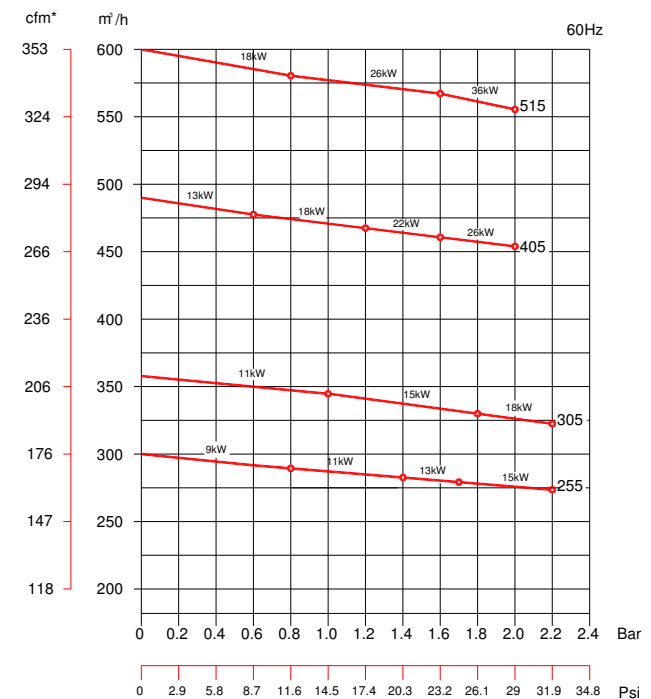
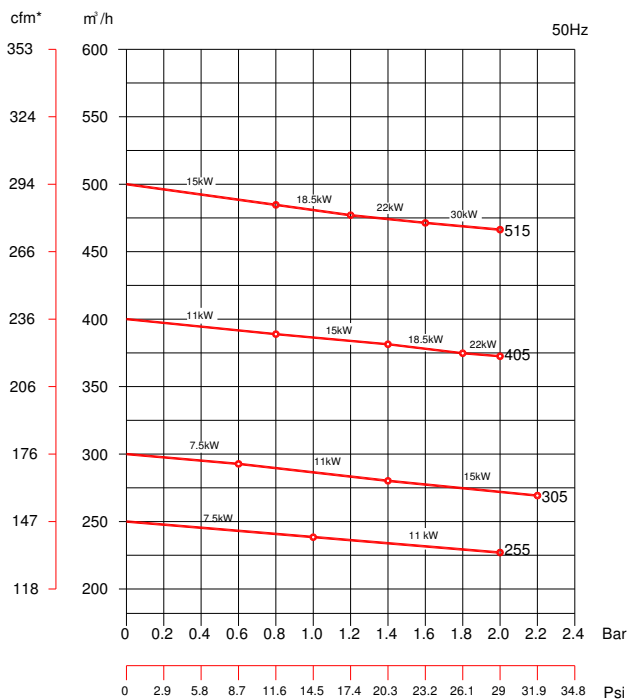

I.VA.CO S.r.l

Via delle Brigole,33 -23877 Paderno d'Adda (LC) - Italy VAT : 09805990968

T: +39.039.9281084

www.ivaco.it - info@ivaco.it

